

UHF Narrow band radio data module

CDP-TX-02E 434 MHz

CDP-TX-02EP 434 MHz



Operation Guide

Version 1.0 (May. 2020)

- This product requires electrical and radio knowledge for setup and operation.
- To ensure proper and safe operation, please read this operation guide thoroughly prior to use.
- Please keep this operation guide for future reference.

CIRCUIT DESIGN, INC.

7557-1 Hotaka, Azumino
Nagano 399-8303 JAPAN
Tel: + +81-(0)263-82-1024
Fax: + +81-(0)263-82-1016

e-mail: info@circuitdesign.jp
<https://www.circuitdesign.jp>

CONTENTS

General description & Features	3
Specifications	4
Pin description.....	5
Channel and frequency settings.....	6
Block diagram.....	8
Dimensions.....	9
Regulatory compliance information.....	10
Important notice.....	11

General description & Features

General description

The CDP-TX-02E and the CDP-TX-02EP are narrowband FM radio transmitter modules suitable for various industrial application fields such as wireless data communication, remote control, telemetry or wireless security systems. They are easy to use and integrate into application systems.

The module is equipped with a frequency synthesizer system with micro controller. The available frequency range is from 433.875 MHz to 434.650 MHz (32 channels: 16 ch x 2 groups).

Features

- Pre-programmed 32 ch in 434 MHz band
- RF power selectable 1 mW / 10 mW
- Wide operating temperature range (-20 to +60 degree C)
- Narrow band FM 25 kHz step
- Operating distance 600 m (when combined with CDP-RX-02E)
- RED and RoHS compliant

Applications

- Radio remote control cranes and machines
- Factory automation M2M
- Security systems
- Alarms
- Telemetry systems

Models

Model name	Channel setting
CDP-TX-02E 434MHz	Dip switches
CDP-TX-02EP 434MHz	Pin connectors

For the CDP-TX-02E, frequency setting is performed with the 4-bit switch. Instead of the 4-bit switch, the CDP-TX-02EP has an 8-pin connector for frequency setting, making it possible to set the channels externally.

There are no other technical and mechanical differences between CDP-TX-02E and CDP-TX-02EP.

Specifications

All ratings at 25°C +/- 5°C unless otherwise noted

Parameter	Rating	Conditions
General characteristics		
Applicable standard	EN 300 220	
Communication method	One way	
Operating frequency range	433.875 – 434.650 MHz	
Operating temperature range	-20 to + 60 °C	No dew condensation
Storage temperature range	-30 to + 70 °C	No dew condensation
Aging rate	Max. +/- 1 ppm / year	RX Local Freq.
Initial freq. tolerance	Max. +/- 2 ppm	At delivery *1
Dimension	26 x 36 x 10 mm	Excluding protrusion
Weight	14 g	Not including the antenna
Electrical specification		
Oscillation system	PLL controlled VCO	
Channel steps	25 kHz	
Number of RF channels	32 channels (16 x 2 groups)	Default channel at delivery B16 (434.650 MHz)
Data rate	300 to 4800 bps	(Pulse length Min. 208 us Max. 20 ms)
Data output level	L = Gnd H = Vcc	
Data polarity	Positive	TX DI vs RX DO
PLL reference frequency	21.25 kHz	TCXO
Antenna impedance	50 ohm	Nominal
Operating voltage	3 – 12 V	
Consumption current (10 mW)	Typ. 43 mA at 3V	Max. 47 mA
Consumption current (1 mW)	Typ. 33 mA at 3V	Max. 37 mA
Transmitter part		
RF output power	10 mW / 1mW	Selectable
Frequency stability	Max. +/- 4 ppm	- 20 to 60°C with reference frequency at 25°C
Deviation	+/- 2.1 kHz +/-0.4 kHz	PN9, 4800 bps, LPF 20 kHz, (-20 to + 60°C)
Residual FM noise	0.17 kHz	DI = L, LPF 20 kHz
Modulation freq. characteristics	+/- 3 dB	50 to 2400 Hz
Spurious emission	- 54 dBm	47M-74M, 87.5M-118M, 174M-230M, 470M –862M
	- 36 dBm	Other frequencies below 1000 MHz
	- 30 dBm	Frequencies above 1000 MHz
Adjacent ch leakage power	-37 dBm	CH 25 kHz, BW 16 kHz, PN9, 4800 bps
Start-up time	50 ms	From power on *2
	35 ms	Time required for channel change (50 kHz step) *3

Specifications are subject to change without prior notice

*1 Initial frequency tolerance: At delivery

Initial frequency tolerance is defined as frequency drift within 1 year after the final adjustment.

*2 Start-up time from power on

Time required for the TX frequency to reach within +/-1.5ppm of a stable frequency after power on.

*3 Start-up time for channel change

Time required for the TX frequency to reach within +/-1.5ppm of a stable frequency after channel is selected.

Pin description

Pin name	I/O	Description	Equivalent circuit
ANT	O	RF output terminal Antenna impedance nominal 50 Ω	
GND	I	The ground for the power supply. Connect it to the ground plane as well as to the bottom part of the case. The ground plane has an impact on the range and the stability of operation.	
VCC	I	The power supply terminal. The supply voltage is DC 3.0 to 12 V. Power supply noise and ripple have an impact on performance, so eliminate them as far as possible with filters and capacitors.	
DATA IN	I	Digital data input terminal Interface voltage: H = Vcc L = GND	

Channel and frequency settings

By use of a chip mounted 4-bit switch or pins and a jumper on the PCB, you can select easily between the 32 channels. The 32 channels are divided into 2 groups: Group A and Group B. Each group of channels can be selected by soldering the jumper ON or OFF. When the jumper (JP2) is ON, Group A is selected. When the jumper is OFF, Group B is selected. There are 16 channels in each group and they can easily be selected using the 4-bit switch or pins. Before shipment all the modules are set to Group B and all the 4 bits of the switch or pins are set to OFF (434.650 MHz).

Channel Table

Ch	Freq. (MHz)	4-bit Switch or PIN status *				Jumper	Ch	Freq. (MHz)	4-bit Switch or PIN status *				Jumper
		1	2	3	4				1	2	3	4	
A1	433.875	ON	ON	ON	ON	ON	B1	433.900	ON	ON	ON	ON	OFF
A2	433.925	OFF	ON	ON	ON	ON	B2	433.950	OFF	ON	ON	ON	OFF
A3	433.975	ON	OFF	ON	ON	ON	B3	434.000	ON	OFF	ON	ON	OFF
A4	434.025	OFF	OFF	ON	ON	ON	B4	434.050	OFF	OFF	ON	ON	OFF
A5	434.075	ON	ON	OFF	ON	ON	B5	434.100	ON	ON	OFF	ON	OFF
A6	434.125	OFF	ON	OFF	ON	ON	B6	434.150	OFF	ON	OFF	ON	OFF
A7	434.175	ON	OFF	OFF	ON	ON	B7	434.200	ON	OFF	OFF	ON	OFF
A8	434.225	OFF	OFF	OFF	ON	ON	B8	434.250	OFF	OFF	OFF	ON	OFF
A9	434.275	ON	ON	ON	OFF	ON	B9	434.300	ON	ON	ON	OFF	OFF
A10	434.325	OFF	ON	ON	OFF	ON	B10	434.350	OFF	ON	ON	OFF	OFF
A11	434.375	ON	OFF	ON	OFF	ON	B11	434.400	ON	OFF	ON	OFF	OFF
A12	434.425	OFF	OFF	ON	OFF	ON	B12	434.450	OFF	OFF	ON	OFF	OFF
A13	434.475	ON	ON	OFF	OFF	ON	B13	434.500	ON	ON	OFF	OFF	OFF
A14	434.525	OFF	ON	OFF	OFF	ON	B14	434.550	OFF	ON	OFF	OFF	OFF
A15	434.575	ON	OFF	OFF	OFF	ON	B15	434.600	ON	OFF	OFF	OFF	OFF
A16	434.625	OFF	OFF	OFF	OFF	ON	B16	434.650	OFF	OFF	OFF	OFF	OFF

* B16: Default setting

4 bit switch: ON = L (GND) OFF = H (Open)

PIN status: ON = L (Short to GND pin) OFF = H (Open)

JP2: Frequency Group Setting (Switch: ON = "L" / OFF = "H")

Group A: Jumper ON Group B: Jumper OFF (Default)

(Example) Set to channel A5 (434.075 MHz)

Group A: JP2: Jumper ON Dip Switch / PIN: ON, ON, OFF, ON (ON: Short to GND)

Position of the JP1, JP2, DIP SW and Pins.

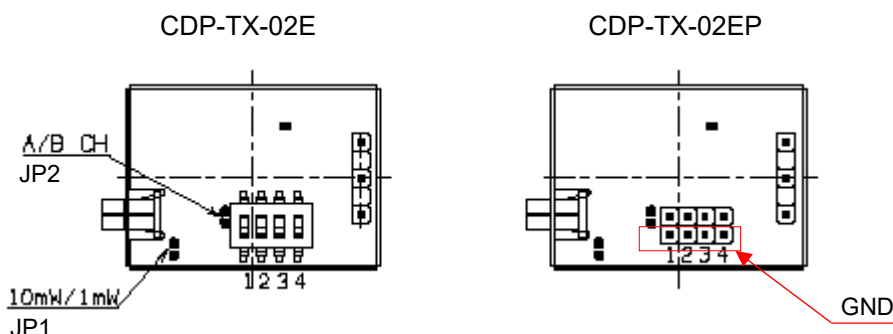

POWER SETTING

CDP-TX-02E(P) can be set to either 10 mW or 1 mW by a jumper on the PCB.

JP1: Power Setting (Switch: ON = “L” / OFF = “H”)

10 mW: Jumper ON (Default) 1 mW: Jumper OFF

Note:

The power level limit of the 434 MHz ISM band in Europe is defined as below. Please choose the maximum power and duty cycle allowed by the regulations.

Frequency band	Power	Duty cycle	Channel spacing
433.050 MHz – 434.790 MHz	10 mW e.r.p.	<10%	No spacing
433.050 MHz – 434.790 MHz	1 mW e.r.p. - 13 dBm/10kHz	Up to 100%	No spacing
434.040 MHz – 434.790 MHz	10 mW e.r.p.	Up to 100%	Up to 25 kHz

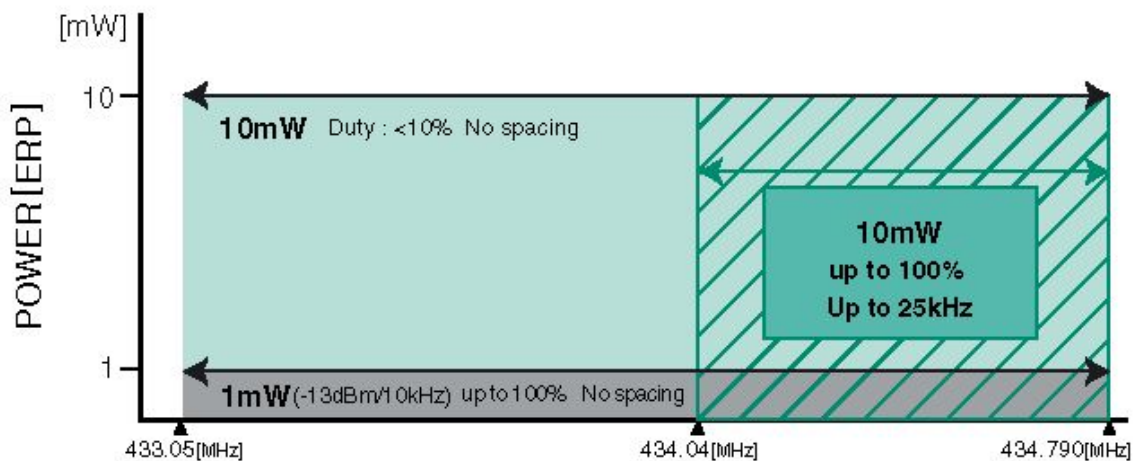

Block diagram

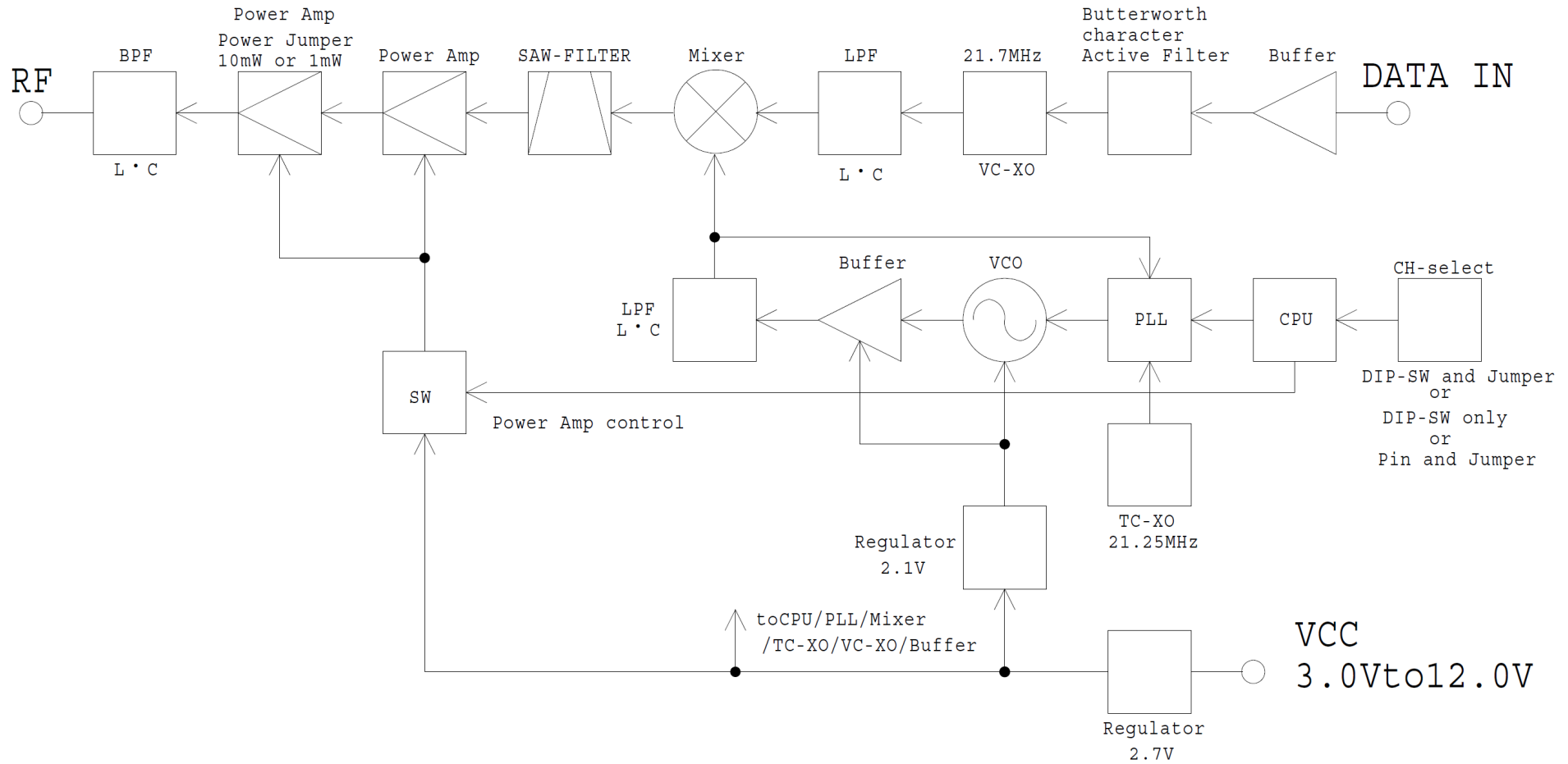

Dimensions

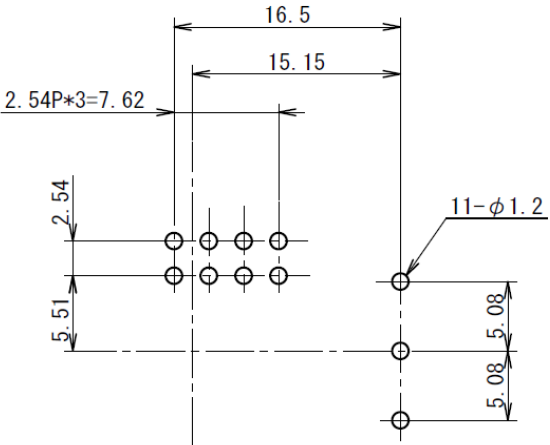
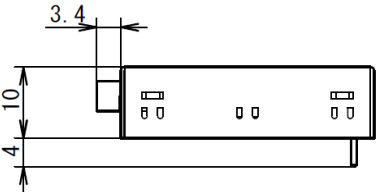
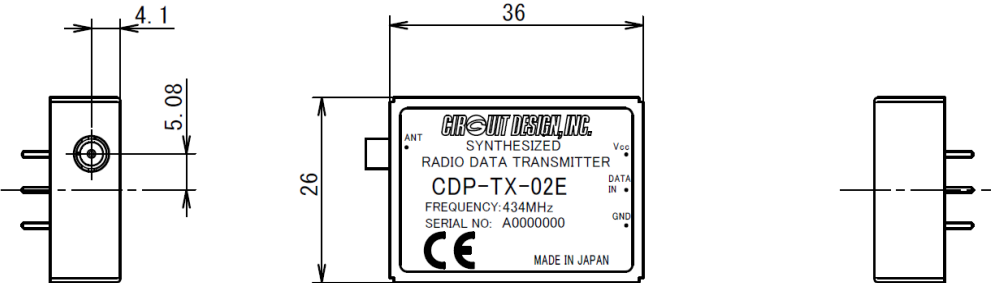

Reference hole position (Top View)

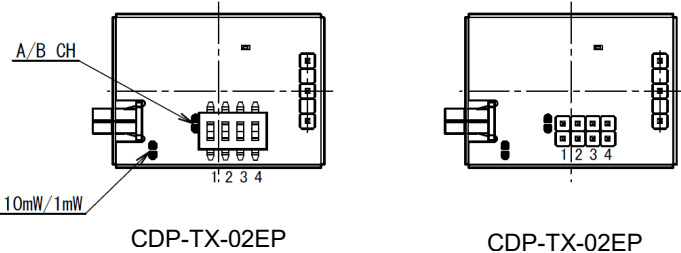

Regulatory compliance information

Declaration of Conformity

Hereby, Circuit Design, Inc. declares that the CDP-TX-02E and the CDP-TX-02EP are in compliance with RE Directive (2014/53/EU).

The full text of the EU Declaration of Conformity is available at www.circuitdesign.jp.

Cautions related to regulatory compliance when embedding the CDP-TX-02E/CDP-TX-02EP

This product requires electrical and radio knowledge for setup and operation.

Duty cycle

The CDP-TX-02E and CDP-TX-02EP are designed to be used in the EU wide harmonised frequency bands for short range devices. The module continuously emits carrier signals when power is supplied. The user must design the final product to meet the relevant duty cycle requirement (For more details, refer to the EN300 220-2).

Antenna

The CDP-TX-02E and CDP-TX-02EP are supplied without a dedicated antenna.

The conformity assessment of the module was performed using Circuit Design's standard antenna ANT-LEA-01 (1/4 lambda lead antenna), so we recommend using the ANT-LEA-01 antenna or an antenna with equivalent characteristics (2.14 dBi or less). For details about our standard antenna, refer to www.circuitdesign.jp or contact us. If you use an antenna other than the recommended antenna, further radio conformity assessment may be required.

Supply voltage

To fulfill the safety requirements, the CDP-TX-02E/CDP-TX-02EP should be connected to a proper power supply within the specified voltage range.

Enclosure

To fulfill the requirements of EMC and safety requirements, the CDP-TX-02E/CDP-TX-02EP should be mounted on the circuit board of the final product and must be enclosed in the case of the final product. No surface of the module should be exposed.

Conformity assessment of the final product

The manufacturer of the final system needs to conduct full EMC testing in the final configuration and also ensure the final product fulfills the health and safety requirements and is also responsible for the conformity assessment procedures of the final product in accordance with the RE Directive.

Important notice

- Customers are advised to consult with Circuit Design sales representatives before ordering. Circuit Design believes the provided information is accurate and reliable. However, Circuit Design reserves the right to make changes to this product without notice.
- Circuit Design products are neither designed nor intended for use in life support applications where malfunction can reasonably be expected to result in significant personal injury to the user. Any use of Circuit Design products in such safety-critical applications is understood to be fully at the risk of the customer and the customer must fully indemnify Circuit Design, Inc for any damages resulting from any improper use.
- As the radio module communicates using electronic radio waves, there are cases where transmission will be temporarily cut off due to the surrounding environment and method of usage. The manufacturer is exempt from all responsibility relating to resulting harm to personnel or equipment and other secondary damage.
- The manufacturer is exempt from all responsibility relating to secondary damage resulting from the operation, performance and reliability of equipment connected to the radio module.

Copyright

- All rights in this operation guide are owned by Circuit Design, Inc. No part of this document may be copied or distributed in part or in whole without the prior written consent of Circuit Design, Inc.

Cautions

- Do not use the equipment within the vicinity of devices that may malfunction as a result of electronic radio waves from the radio module.
- Communication performance will be affected by the surrounding environment, so communication tests should be carried out before actual use.
- Ensure that the power supply for the radio module is within the specified rating. Short circuits and reverse connections may result in overheating and damage and must be avoided at all costs.
- Ensure that the power supply has been switched off before attempting any wiring work.
- The case is connected to the GND terminal of the internal circuit, so do not make contact between the '+' side of the power supply terminal and the case.
- When batteries are used as the power source, avoid short circuits, recharging, dismantling, and pressure. Failure to observe this caution may result in the outbreak of fire, overheating and damage to the equipment. Remove the batteries when the equipment is not to be used for a long period of time. Failure to observe this caution may result in battery leaks and damage to the equipment.
- Do not use this equipment in vehicles with the windows closed, in locations where it is subject to direct sunlight, or in locations with extremely high humidity.
- The radio module is neither waterproof nor splash proof. Ensure that it is not splashed with soot or water. Do not use the equipment if water or other foreign matter has entered the case.
- Do not drop the radio module or otherwise subject it to strong shocks.
- Do not subject the equipment to condensation (including moving it from cold locations to locations with a significant increase in temperature.)
- Do not use the equipment in locations where it is likely to be affected by acid, alkalis, organic agents or corrosive gas.
- Do not bend or break the antenna. Metallic objects placed in the vicinity of the antenna will have a great effect on communication performance. As far as possible, ensure that the equipment is placed well away from metallic objects.
- The GND for the radio module will also affect communication performance. If possible, ensure that the case GND and the circuit GND are connected to a large GND pattern.

Warnings

- Do not take a part or modify the equipment.
- Do not remove the product label (the label attached to the upper surface of the module.) Using a module from which the label has been removed is prohibited.

Copyright 2020, Circuit Design, Inc.

Revision history

Version	Date	Description	Remark
1.0	May 2020	The first issue	