

UHF Narrow band radio data module
CDP-TX-07M 869MHz
CDP-TX-07MP 869MHz



Operation Guide

Version 1.0 (Oct. 2022)

CIRCUIT DESIGN, INC.,

7557-1 Hotaka, Azumino
Nagano 399-8303 JAPAN
Tel: + +81-(0)263-82-1024
Fax: + +81-(0)263-82-1016

e-mail: info@circuitdesign.jp
<http://www.circuitdesign.jp>

CONTENTS

GENERAL DESCRIPTION & FEATURES	3
SPECIFICATIONS	4
PIN DESCRIPTION	5
OPERATING INSTRUCTIONS	7
BLOCK DIAGRAM	8
DIMENSIONS	9
REGULATORY COMPLIANCE INFORMATION	11
IMPORTANT NOTICE	13
CAUTIONS	13
WARNINGS	13

GENERAL DESCRIPTION & FEATURES

General description

The CDP-TX-07M and the CDP-TX-07MP are low power narrow band FSK transmitter modules and include nearly all the parts necessary for industrial-use radio transmission in a small and robust shielding case.

Using a TCXO as the reference oscillator circuit of the radio component ensures high frequency stability and a wide operating temperature range from -20°C to $+65^{\circ}\text{C}$.

The CDP-TX-07M/CDP-TX-07MP is compatible with the CDP-TX-05M/CDP-TX-05MP in shape and function, and provides equivalent performance.

The RF channel is selectable from four preset frequency channels and set by the solder jumpers on the bottom side of the module and with the CDP-TX-07MP, it can also be set through the connector pins.

Furthermore, with the CDP-TX-07MP, the user can reprogram each channel with a frequency selected from 155 frequencies in the 869 MHz band using a dedicated setting program. For details of the dedicated setting program and how to reprogram the frequency channels, refer to the application note "*How to reprogram the preset frequencies of the CDP-TX-07MP/CDP-RX-07MP*".

Features

- Low power narrow band FSK - 25 kHz channel spacing
- 4 preset RF channels
- Low voltage operation
- Wide operating temperature range (-20°C to $+65^{\circ}\text{C}$) / TCXO built in
- 600 m line of sight - when combined with CDP-RX-07M/CDP-RX-07MP
- Compact size
- RoHS / RED compliant

Applications

- Industrial remote control
- Security / Alarms
- Telemetry / Monitoring systems
- Tracking systems

SPECIFICATIONS

All ratings at 25°C +/- 5°C unless otherwise noted

Item	Specification								
Applicable standard	EN 300 220								
Communication form	One way								
Oscillation system	Crystal based PLL oscillation								
Number of channels	4								
Frequencies [MHz]	<table border="0"> <tr> <td>CH 3*</td> <td>869.7500 *</td> </tr> <tr> <td>CH 2</td> <td>868.3000</td> </tr> <tr> <td>CH 1</td> <td>869.8000</td> </tr> <tr> <td>CH 0</td> <td>869.9250</td> </tr> </table>	CH 3*	869.7500 *	CH 2	868.3000	CH 1	869.8000	CH 0	869.9250
CH 3*	869.7500 *								
CH 2	868.3000								
CH 1	869.8000								
CH 0	869.9250								
* Factory default frequency channel setting. Frequency setting can be done with the jumpers and also the channel select pins are available with the CDP-TX-07MP. For details, refer to PIN DESCRIPTION.									
Frequency stability	< +/- 2.5 ppm (-20 to + 65 °C, reference frequency = 25 °C)								
Aging rate	< +/- 1 ppm / Year								
Initial frequency tolerance at delivery	< +/- 1.5 ppm (within 1 year after the final adjustment)								
Pulse width	208 us - 20 ms								
Data rate (FSK)	100 - 4,800 bps								
Operating temp. range	-20 °C to + 65 °C								
RF output power (e.r.p. , 50 ohms)	< 5 mW								
Transmitter start up time	< 20 ms								
Modulation	FM narrow								
Modulation polarity	Positive								
Deviation	+/- 3 kHz								
Spurious emission	<table border="0"> <tr> <td>< 790MHz</td> <td>< -54 dBm</td> </tr> <tr> <td>790MHz-1GHz</td> <td>< -36 dBm</td> </tr> <tr> <td>> 1GHz</td> <td>< -30 dBm</td> </tr> </table>	< 790MHz	< -54 dBm	790MHz-1GHz	< -36 dBm	> 1GHz	< -30 dBm		
< 790MHz	< -54 dBm								
790MHz-1GHz	< -36 dBm								
> 1GHz	< -30 dBm								
Adjacent channel power	< -37 dBm (200 nW) (4800PN code CH=25kHz)								
Supply voltage	2.2 to 5.5 V								
Supply current (Typ. at 3.0V)	18 mA								
I/O terminals	RFout, Gnd, Vcc, Datain Channel select, Mode (CDP-TX-07MP)								
Dimension	21.4 x 12 x 4.5 mm								
Weight	2 g								

CDP-TX-07MP reprogrammable frequency channels

Each of the 4 preset channels are reprogrammable using values chosen from a frequency table containing 155 values that consists of values from 868.050 MHz to 869.975 MHz.

To reprogram the preset channels, a dedicated setting program is provided.

For details, refer to the application note "How to reprogram the preset frequencies of the CDP-TX-07MP/CDP-RX-07MP".

PIN DESCRIPTION

CDP-TX-07M

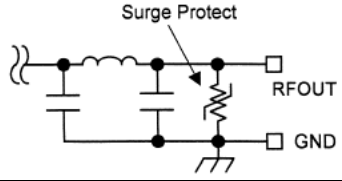
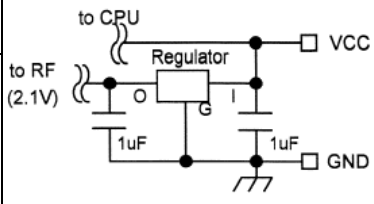
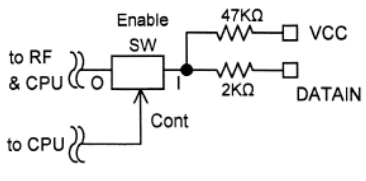
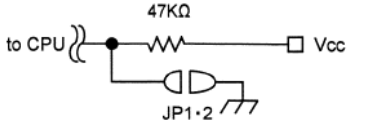
Pin-No.	Pin-Name	I/O	Description	Equivalent internal circuit
1	RFOUT	O	Z=50 ohm 1/4 lambda whip antenna is recommended.	
2	GND	-	The ground Please connect to the widest GND on the PCB.	
3	VCC	-	The power supply terminal Operates on DC 2.2 V to 5.5 V. If the voltage becomes lower than 2.2 V, RF characteristics such as frequency stability will be affected.	
4	DATAIN	I	The data input terminal Digital input. Hi level = VCC Lo level = 0V Stable transmission will be obtained 20 ms (max.) after VCC is fed to the terminal. The maximum time for continuous High or Low signals must be within 20 ms. When this pin is open, the frequency has an offset drift. Once a standard code such as 511PNCODE has been input, the frequency will be within specifications.	
	JP1/JP2	I	Solder jumpers for frequency channel setting. This terminal is pulled-up to the VCC. Ch3 (JP1-Open JP2-Open) Ch2 (JP1-Short JP2-Open) Ch1 (JP1-Open JP2-Short) Ch0 (JP1-Short JP2-Short)	

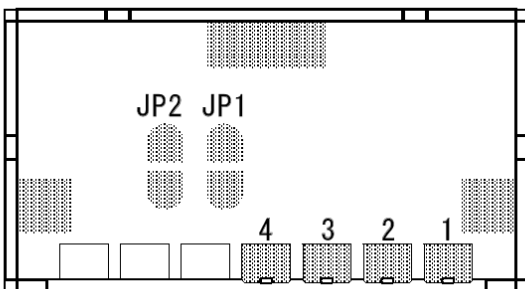

CDP-TX-07MP

Pin-No.	Pin-Name	I/O	Description	Equivalent internal circuit
1	RFOUT	O	Z=50 ohm 1/4 lambda whip antenna is recommended.	
2	GND	-	The ground Please connect to the widest GND on the PCB.	
3	VCC	-	The power supply terminal Operates on DC 2.2 V to 5.5 V. If the voltage becomes lower than 2.2 V, RF characteristics such as frequency stability will be affected.	
4	DATAIN	I	The data input terminal Digital input. Hi level = VCC Lo level = 0V Stable transmission will be obtained 20 ms (max.) after VCC is fed to the terminal. The maximum time for continuous High or Low signals must be within 20 ms. When this pin is open, the frequency has an offset drift. Once a standard code such as 511PNCODE has been input, the frequency will be within specifications.	
5	MODE	I	Normally leave this terminal open. Setting this terminal to Low enables the user to reprogram the 4 preset channels by using a dedicated setting program. For details of how to reprogram the preset channels, refer to the application note.	
6	S1	I	These terminals are pulled-up to the VCC. Set the terminal to Open or Gnd-Short to select the channel. The frequency channel can be set as follows: Ch3 (S1-Open, S2-Open) Ch2 (S1-Short, S2-Open) Ch1 (S1-Open, S2-Short) Ch0 (S1-Short, S2-Short)	
7	S2	I	Via S1 and S2, the user can reprogram the 4 frequency channels to preset by using a dedicated setting program. For details of how to reprogram the preset channels, refer to the application note.	

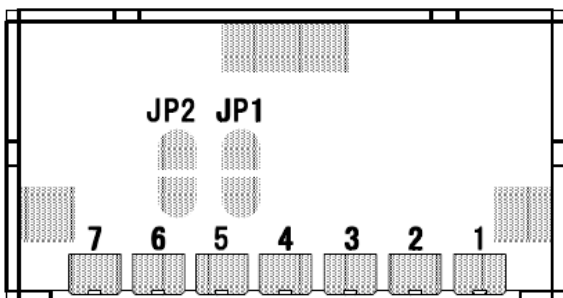

The solder jumpers JP1 and JP2 are internally connected to the pin # 6 and pin #7, respectively.

OPERATING INSTRUCTIONS

Supply voltage

The CDP-TX-07M/CDP-TX-07MP contain a voltage regulator to guarantee stable performance in the given range of supply voltage. The design was made for operation with a battery. The supply voltage must be within the specified voltage range. The module shows unstable function with a voltage lower than specified

If a higher supply voltage is available, a simple diode can be inserted in the connection line to the Vcc terminal to prevent damage due to incorrect polarity. The diode must be rated for the maximum supply current detailed in the technical specifications.

DATA IN

Digital input. The voltage of the data signal should be between 0 V and Vcc.

When High (Vcc level) is input in DATAIN, High will be output from DO of the CDP-RX-07M, and when Low (GND level) is input, Low will be output. DATAIN is pulled-up to the VCC. If the data level is lower or higher than the Vcc level, it can be driven by an open-collector transistor /device.

It is not necessary to synchronize the data signal of the transmitter, but the data signal should be fed to the transmitter 20 ms after the transmitter power is turned on.

Data format

Long intervals of HIGH or LOW bits should be avoided. Succeeding bits can be distorted in their pulse width. If the sequence of HIGH or LOW bits is too long, then there is a possibility that the logic level of the data output will change. The maximum pulse width for continuous High and Low signal is 20 ms (96 bits) at 4800 bps. The minimum pulse width is 208 us. Maximum data rate is 4800 bps.

It is good to have a 20bit preamble (1010...) in front of the data to ensure communication reliability.

In general, at higher data rates (4800 Baud) the internal signal is shaped into a slope and jitter at the receiver data output increases.

Further advice can be given if the precise format of the data and system requirements are notified to the dealer or directly to Circuit Design, Inc. Your inquiries and comments are welcome.

Antennas

Connect an antenna of 50 Ω impedance according to the frequency to be used. Note that the performance of the antenna changes significantly depending on the connection condition, shape, and surrounding environment, and it affects the reception sensitivity and distance.

BLOCK DIAGRAM

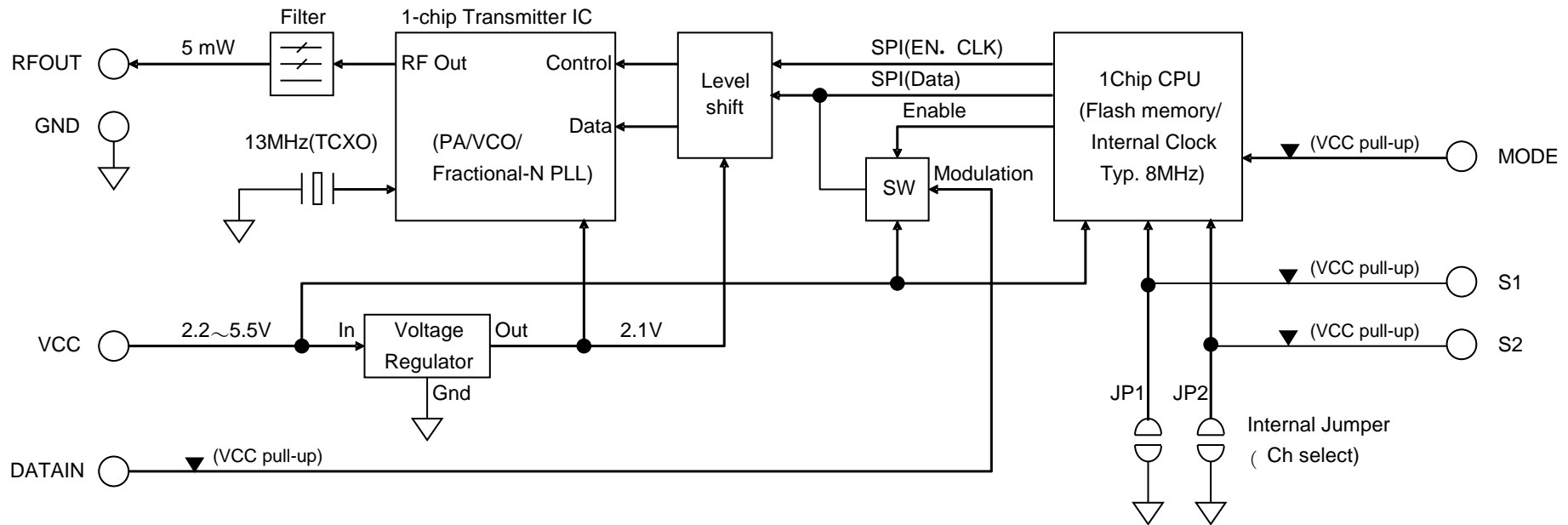

NOTE:

MODE, S1 and S2 terminals are only available with the CDP-TX-07MP.

DIMENSIONS

CDP-TX-07M

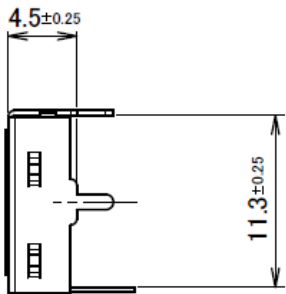
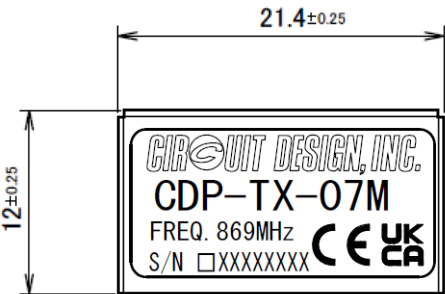
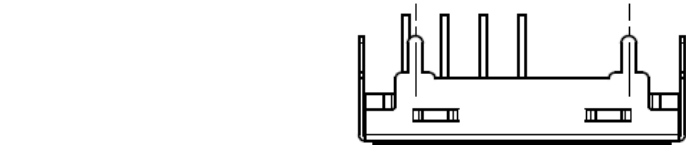

Reference hole position for PCB mounting
(Top view)

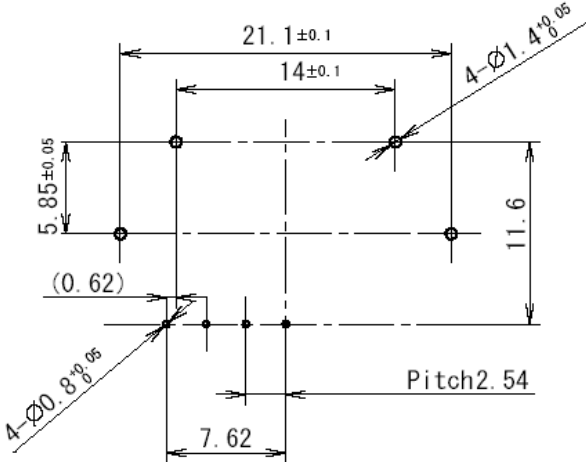

- 1. RF OUT
- 2. GND
- 3. VCC
- 4. DATA IN

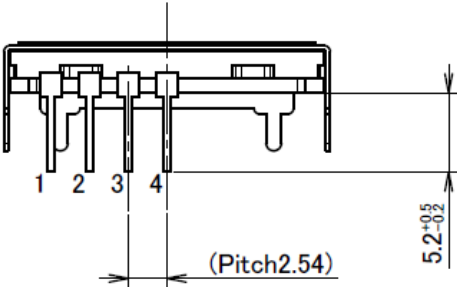

CDP-TX-07MP

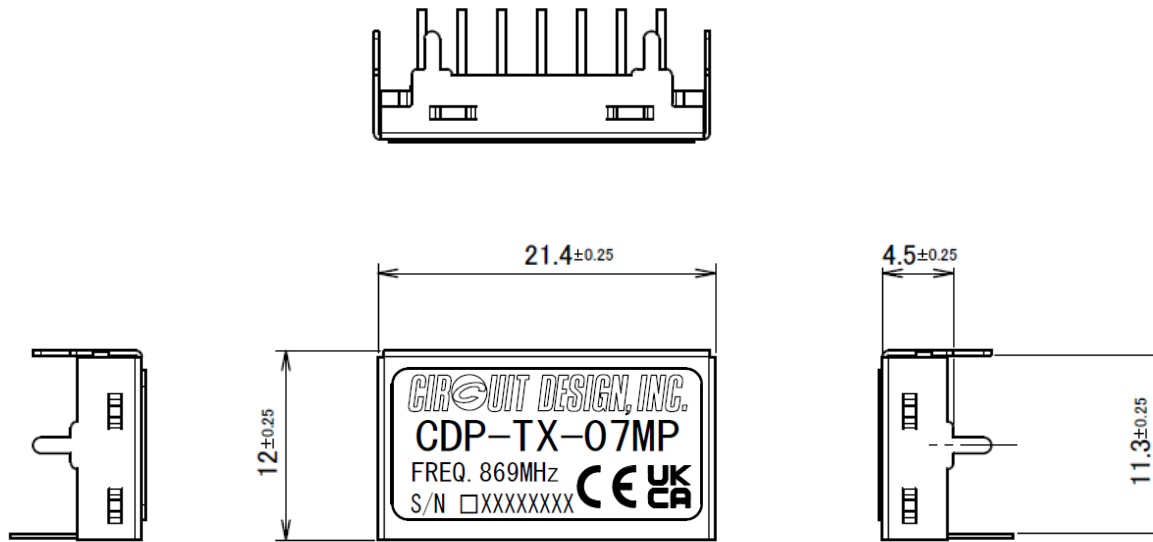

Reference hole position for PCB mounting
(Top view)

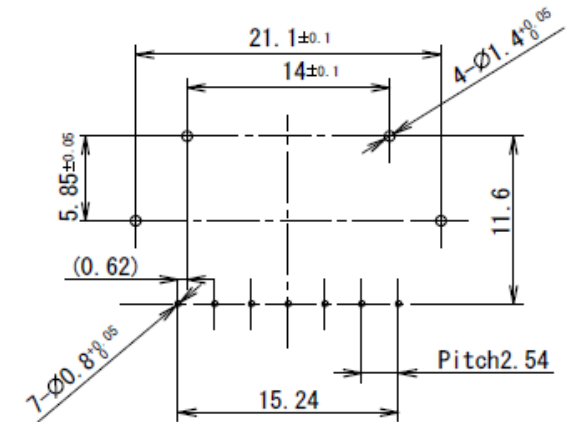

1. RF OUT
2. GND
3. VCC
4. DATA IN
5. MODE
6. S1
7. S2

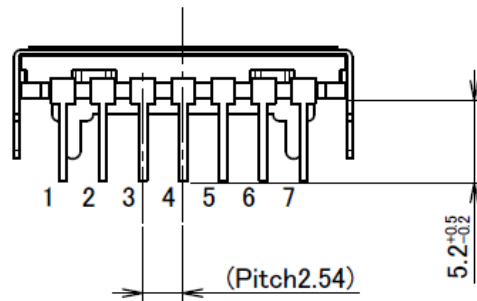

Regulatory compliance information

Declaration of Conformity

Hereby, Circuit Design, Inc. declares that the CDP-TX-07M and the CDP-TX-07MP are in compliance with RE Directive (2014/53/EU).

The full text of the EU Declaration of Conformity is available at www.circuitdesign.jp.

Cautions related to regulatory compliance when embedding the CDP-TX-07M/CDP-TX-07MP

This product requires electrical and radio knowledge for setup and operation.

Applications and Duty cycle

The CDP-TX-07M/CDP-TX-07MP 869MHz is designed to be used in Non-specific short range applications and Alarm systems (not including Social alarms) covered by EN 300 220-2 and EN 300 220-3-2.

The CDP-TX-07M/CDP-TX-07MP emits carrier signals when power is supplied.

Ensure that you use the frequencies allocated to your application and design the final product to meet the relevant duty cycle requirement.

The table below shows the regulatory parameters set out in ERC Recommendation 70-03.

For more details, refer to the relevant part of the EN 300 220 and/or consult the relevant authorities

Regulatory parameters for 868 - 870 MHz band

Frequency band	Application	RF power	Spectrum access and mitigation requirements
868 - 868.6 MHz	Non Specific SRD	25 mW e.r.p.	≤ 1% duty cycle or LBT+AFA
868.6 - 868.7 MHz	Alarms	10 mW e.r.p.	≤ 1% duty cycle
868.7 - 869.2 MHz	Non Specific SRD	25 mW e.r.p.	≤ 0.1% duty cycle or LBT+AFA
869.2 - 869.25 MHz	Social alarms	10 mW e.r.p.	≤ 0.1% duty cycle
869.25 - 869.3 MHz	Alarms	10 mW e.r.p.	≤ 0.1% duty cycle
869.3-869.4 MHz	Alarms	10 mW e.r.p.	≤ 1% duty cycle
869.4-869.65 MHz	Non Specific SRD	500 mW e.r.p.	≤ 10% duty cycle or LBT+AFA
869.65-869.7 MHz	Alarms	25 mW e.r.p.	≤ 10% duty cycle
869.7-870 MHz	Non Specific SRD	5 mW e.r.p.	No requirement
869.7-870 MHz	Non Specific SRD	25 mW e.r.p.	≤ 1% duty cycle or LBT+AFA

Reference : ERC Recommendation 70-03 Feb. 11. 2022

Antenna

The CDP-TX-07M/CDP-TX-07MP is supplied without a dedicated antenna.

The conformity assessment was performed using Circuit Design’s standard antenna ANT-LEA-02, so we recommend using the ANT-LEA-02 or an antenna with equivalent characteristics (2.14 dBi or less). For details about our standard antenna, refer to www.circuitdesign.jp or contact us. If you use an antenna other than the recommended antenna, further radio conformity assessment may be required.

Supply voltage

To fulfill the safety requirements, the CDP-TX-07M/CDP-TX-07MP should be connected to a proper power supply within the specified voltage range.

Enclosure

To fulfill the requirements of EMC and safety requirements, the CDP-TX-07M/CDP-TX-07MP should be mounted on the circuit board of the final product and must be enclosed in the case of the final product. No surface of the module should be exposed.

Conformity assessment of the final product

The manufacturer of the final system needs to conduct full EMC testing in the final configuration and also ensure the final product fulfills the health and safety requirements and is also responsible for the conformity assessment procedures of the final product in accordance with the RE Directive.

Important notice

- Customers are advised to consult with Circuit Design sales representatives before ordering. Circuit Design believes the provided information is accurate and reliable. However, Circuit Design reserves the right to make changes to this product without notice.
- Circuit Design products are neither designed nor intended for use in life support applications where malfunction can reasonably be expected to result in significant personal injury to the user. Any use of Circuit Design products in such safety-critical applications is understood to be fully at the risk of the customer and the customer must fully indemnify Circuit Design, Inc for any damages resulting from any improper use.
- As the radio module communicates using electronic radio waves, there are cases where transmission will be temporarily cut off due to the surrounding environment and method of usage. The manufacturer is exempt from all responsibility relating to resulting harm to personnel or equipment and other secondary damage.
- The manufacturer is exempt from all responsibility relating to secondary damage resulting from the operation, performance and reliability of equipment connected to the radio module.

Copyright

- All rights in this operation guide are owned by Circuit Design, Inc. No part of this document may be copied or distributed in part or in whole without the prior written consent of Circuit Design, Inc.

Cautions

- Do not use the equipment within the vicinity of devices that may malfunction as a result of electronic radio waves from the radio module.
- Communication performance will be affected by the surrounding environment, so communication tests should be carried out before actual use.
- Ensure that the power supply for the radio module is within the specified rating. Short circuits and reverse connections may result in overheating and damage and must be avoided at all costs.
- Ensure that the power supply has been switched off before attempting any wiring work.
- The case is connected to the GND terminal of the internal circuit, so do not make contact between the '+' side of the power supply terminal and the case.
- When batteries are used as the power source, avoid short circuits, recharging, dismantling, and pressure. Failure to observe this caution may result in the outbreak of fire, overheating and damage to the equipment. Remove the batteries when the equipment is not to be used for a long period of time. Failure to observe this caution may result in battery leaks and damage to the equipment.
- Do not use this equipment in vehicles with the windows closed, in locations where it is subject to direct sunlight, or in locations with extremely high humidity.
- The radio module is neither waterproof nor splash proof. Ensure that it is not splashed with soot or water. Do not use the equipment if water or other foreign matter has entered the case.
- Do not drop the radio module or otherwise subject it to strong shocks.
- Do not subject the equipment to condensation (including moving it from cold locations to locations with a significant increase in temperature.)
- Do not use the equipment in locations where it is likely to be affected by acid, alkalis, organic agents or corrosive gas.
- Do not bend or break the antenna. Metallic objects placed in the vicinity of the antenna will have a great effect on communication performance. As far as possible, ensure that the equipment is placed well away from metallic objects.
- The GND for the radio module will also affect communication performance. If possible, ensure that the case GND and the circuit GND are connected to a large GND pattern.

Warnings

- Do not take a part or modify the equipment.
- Do not remove the product label (the label attached to the upper surface of the module.) Using a module from which the label has been removed is prohibited.

Copyright 2022, Circuit Design, Inc.

REVISION HISTORY

Version	Date	Description	Remark
1.0	Oct. 2022	First issue	