

UHF Narrow band multi channel transceiver

LMD-401



Operation Guide

Version 1.0 (May. 2020)

CIRCUIT DESIGN, INC.,

7557-1 Hotaka, Azumino
Nagano 399-8303 JAPAN
Tel: + +81-(0)263-82-1024
Fax: + +81-(0)263-82-1016

e-mail: info@circuitdesign.jp
<http://www.circuitdesign.jp>

CONTENTS

GENERAL DESCRIPTION & FEATURES.....	3
SPECIFICATIONS.....	4
PIN DESCRIPTION.....	6
BLOCK DIAGRAM.....	8
DIMENSIONS.....	9
PLL IC CONTROL.....	10
PLL IC control.....	10
How to calculate the setting values for the PLL register.....	11
Method of serial data input to the PLL.....	12
TIMING CHART.....	13
PLL FREQUENCY SETTING REFERENCE.....	15
REGULATORY COMPLIANCE INFORMATION.....	17
CAUTIONS & WARNINGS.....	21

GENERAL DESCRIPTION & FEATURES

General Description

The LMD-401 is a synthesized multi-channel transceiver module for use under the Land Mobile Radio services (FCC Part 90, ISED RSS-119). This simple, compact and low power transceiver is designed for embedding in user's portable or fixed equipment and suitable for various low power industrial telecontrol and telemetry applications requiring high performance and reliability.

All high frequency circuits are enclosed inside a robust housing to provide superior resistance against shock and vibration. Using a TCXO as the reference oscillator circuit of the radio component ensures high frequency stability in the temperature range from -20 to +65 °C.

The LMD-401 is the same size and pin-compatible with Circuit Design's EN 300 220 compliant license-exempt transceiver model STD-302Z that has been widely used as a standard transceiver for remote control in industrial radio applications.

Features

- Programmable RF channel with 12.5 kHz channel space
- 10 mW, GFSK, 4800 bps
- Low power operation 3 - 5.5 V, 46 mA/TX, 36 mA/RX
- High receiver selectivity & blocking
- Small size 50 x 30 x 9 mm
- Excellent mechanical durability, high vibration & shock resistance
- Wide operation range - 20 to +65 °C
- FCC part 90 and ISED RSS-119 certified

Applications

- Industrial remote control
- Telemetry
- Remote monitoring / Security
- Data acquisition/ SCADA

SPECIFICATIONS

LMD-401

All ratings at 25 +/-10 °C unless otherwise noted

General characteristics

Item	Units	MIN	TYP	MAX	Remarks
Applicable standard		FCC Part 90.217, ISED RSS-119			
Communication method		Simplex, Half-duplex			
Emission class		F1D			
Modulation type		GFSK			
Operating frequency range	MHz	458.000		462.500	
Operation temperature range	°C	-20		65	No dew condensation
Storage temperature range	°C	-30		75	No dew condensation
Aging rate	ppm	-1		1	TX freq., RX Lo freq.
Initial frequency tolerance	ppm	-1		1	TX freq., RX Lo freq.
Dimensions	mm	30 x 50 x 9 mm			Not including antenna
Weight	g	25 g			

Electrical specification <Common>

Item	Units	MIN	TYP	MAX	Remarks
Oscillation type		PLL controlled VCO			
Frequency stability (-20 to 65°C)	ppm	-2.5		2.5	Reference frequency at 25 °C
TX/RX switching time	ms		15	20	DI/DO
Channel step	kHz		12.5		
Data rate	bps	2400		4800	DO/DI
Max. pulse width	ms		15	20	DO/DI
Min. pulse width	us	200			DO/DI
Data polarity		Positive			DO/DI
PLL reference frequency	MHz		21.25		TCXO
PLL response	ms		30	60	from PLL setting to LD out
Antenna impedance	Ω		50		Nominal
Operating voltage	V	3.0		5.5	
TX consumption current	mA		46	50	Vcc = 3.0 V
RX consumption current	mA		36	40	Vcc = 3.0 V

Transmitter part

Item	Units	MIN	TYP	MAX	Remarks
RF output power*	mW		10		Conducted 50 Ω
Deviation	kHz	+/-2.0	+/-2.4	+/-2.8	PN9 4800 bps
DI input level	V	0		5.5	L= GND, H = 3 V- Vcc
Residual FM noise	kHz		0.12		DI=L, LPF=20 kHz
Spurious emission	dBm			-37	< 1000 MHz, conducted 50 Ω
				-31	> 1000 MHz, conducted 50 Ω
Adjacent CH power	dBm			-20	+/-12.5 kHz, PN9 4800
Alternate adjacent CH power	dBm			-20	+/-25 kHz, PN9 4800
Occupied bandwidth	kHz		8.5		PN9 4800

* The RF output power cannot be changed or adjusted.

Receiver part

Item		MIN	TYP	MAX	Remarks
Receiver type		Double superheterodyne			
1st IF frequency	MHz		21.7		
2nd IF frequency	kHz		450		
Maximum input level	dBm			10	
BER (0 error/2556 bits) *1	dBm		-113		PN 9 4800bps
BER (1 % error) *2	dBm		-116		PN 9 4800bps
Sensitivity 12dB/ SINAD	dBm		-116		fm1 k/ dev 2.4 kHz CCITT
Co-channel rejection	dB		-7		D/U ratio
Spurious response rejection	dBm	-44			1 st Mix, 2 nd Mix, 2 signal method
Adjacent CH selectivity	dBm	-50			+/- 12.5 kHz, 2 signal method
Adjacent CH saturation	dBm	-20			+/- 12.5 kHz, 2 signal method
Blocking	dBm	-20			+/-2 MHz, +/-10MHz, +/-5% 2 signal method
DO output level	V			2.8	L = GND H = 2.8 V
RSSI rising time	ms		30	50	CH shift of 25 kHz (from PLL setup)
			50	70	When power ON (from PLL setup)
Time until valid Data-out *3	ms		50	100	CH shift of 25 kHz (from PLL setup)
			70	120	When power ON (from PLL setup)
Spurious radiation (1 st Lo)	dBm		-60	-57	Conducted 50 Ω
RSSI	mV	260	310	360	With -100 dBm
		190	240	290	With -110 dBm

Specifications are subject to change without prior notice

Notice

- The time required until a stable DO is established may get longer due to the possible frequency drift caused by operation environment changes, especially when switching from TX to RX, from RX to TX and changing channels. Please make sure to optimize the timing. The recommended preamble is more than 20 ms.
- Antenna connection is designed as pin connection.
- RF output power, sensitivity, spurious emission and spurious radiation levels may vary with the pattern used between the RF pin and the coaxial connection. Please make sure to verify those parameters before use.
- The feet of the shield case should be soldered to the wide GND pattern to avoid any change in characteristics.

Notes about the specification values

- *1 BER: RF level where no error per 2556 bits is confirmed with the signal of PN9 and 4800 bps.
- *2 BER (1 % error) : RF level where 1% error per 2556 bits is confirmed with the signal of PN9 and 4800 bps.
- *3 Time until valid Data-out : Valid DO is determined at the point where Bit Error Rate meter starts detecting the signal of 4800 bps, 1010 repeated signal.

All specifications are specified based on the data measured in a shield room using the PLL setting controller board prepared by Circuit Design.

PIN DESCRIPTION

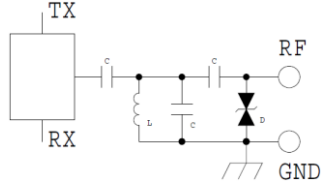
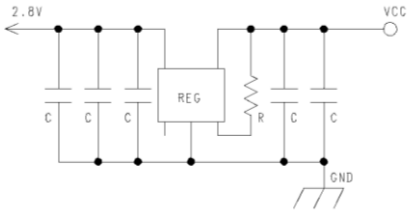
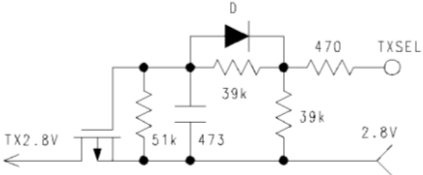
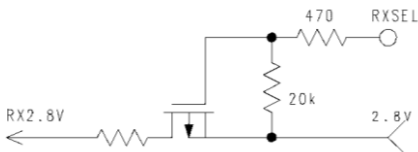
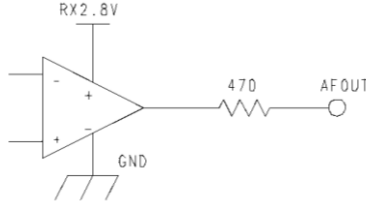
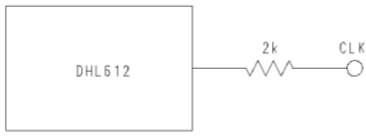
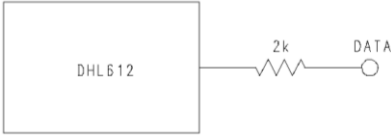
Pin name	I/O	Description	Equivalent circuit
RF	I/O	RF input terminal Antenna impedance nominal 50 Ω	
GND	I	GROUND terminal The GND pins and the feet of the shield case should be connected to the wide GND pattern.	
VCC	I	Power supply terminal DC 3.0 to 5.5 V	
TXSEL	I	TX select terminal GND = TXSEL active To enable the transmitter circuits, connect TXSEL to GND and RXSEL to OPEN or 2.8 V.	
RXSEL	I	RX select terminal GND= RXSEL active To enable the receiver circuits, connect RXSEL to GND and TXSEL to OPEN or 2.8 V.	
AFOUT	O	Analogue output terminal There is DC offset of approx. 1 V. Refer to the specification table for amplitude level.	
CLK	I	PLL data setting input terminal Interface voltage H = 2.8 V, L = 0 V	
DATA	I	PLL data setting input terminal Interface voltage H = 2.8 V, L = 0 V	

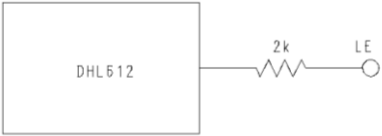
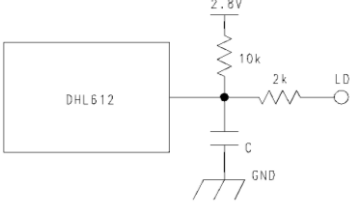
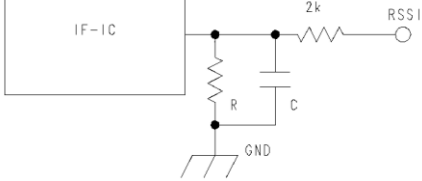
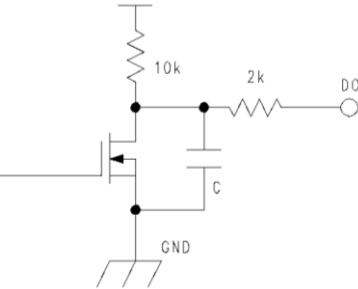
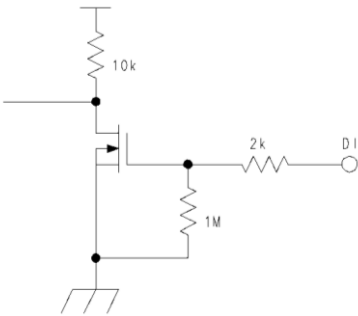
<p>LE</p>	<p>I</p>	<p>PLL data setting input terminal Interface voltage H = 2.8 V, L = 0 V</p>	
<p>LD</p>	<p>O</p>	<p>PLL lock/unlock monitor terminal Lock = H (2.8 V), Unlock = L (0 V)</p>	
<p>RSSI</p>	<p>O</p>	<p>Received Signal Strength Indicator terminal</p>	
<p>DO</p>	<p>O</p>	<p>Data output terminal Interface voltage: H=2.8V, L=0V</p>	
<p>DI</p>	<p>I</p>	<p>Data input terminal Interface voltage: H=2.8V to Vcc, L=0V Input data pulse width Min.100 μs Max. 15 ms</p>	

BLOCK DIAGRAM

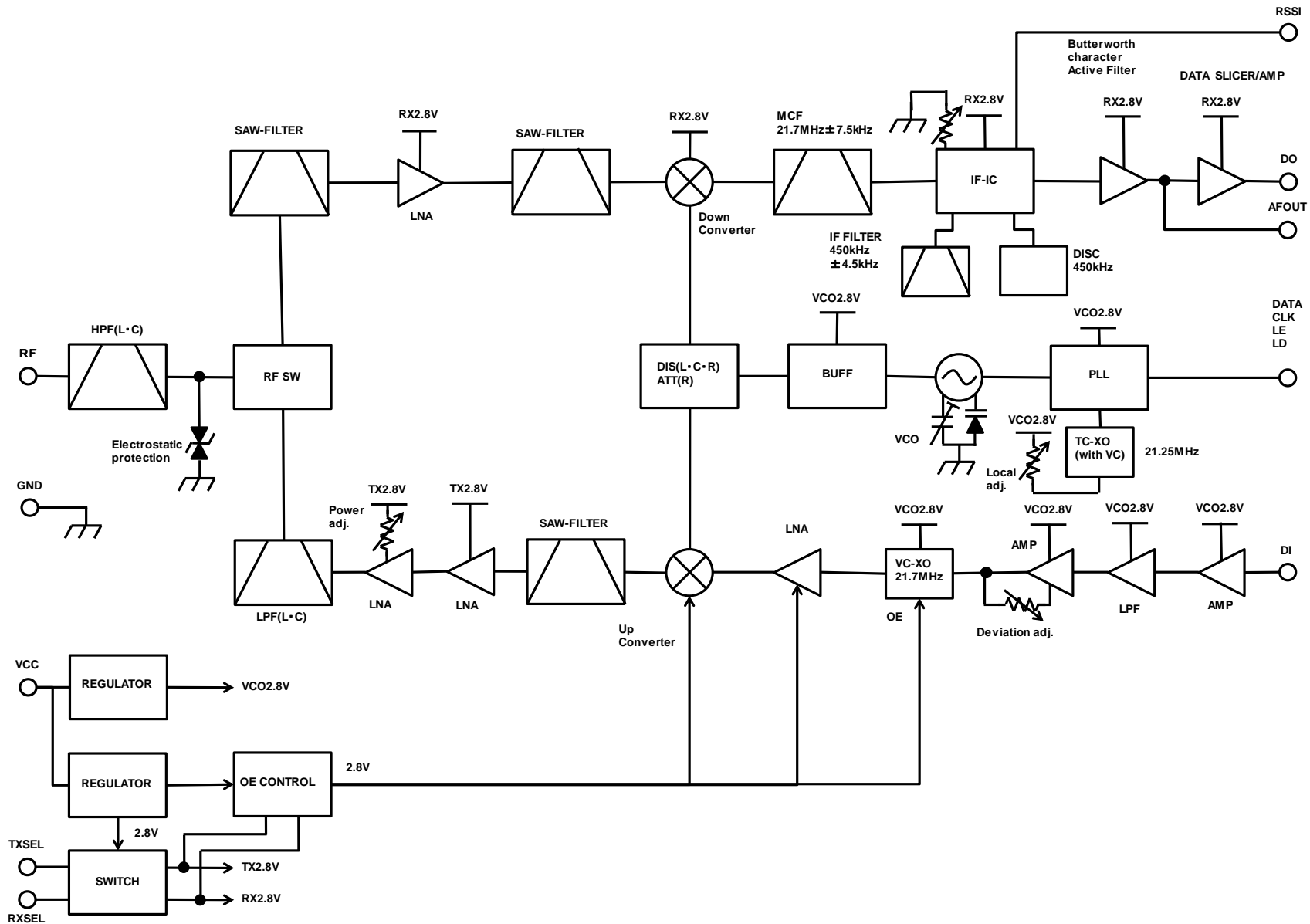

DIMENSIONS

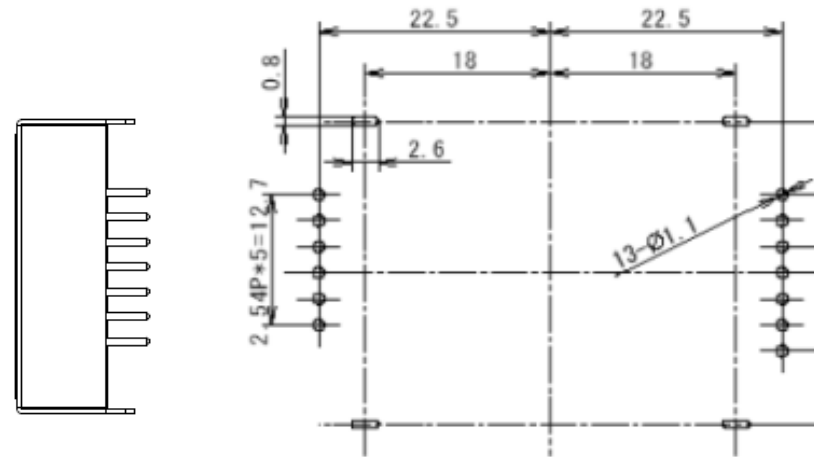
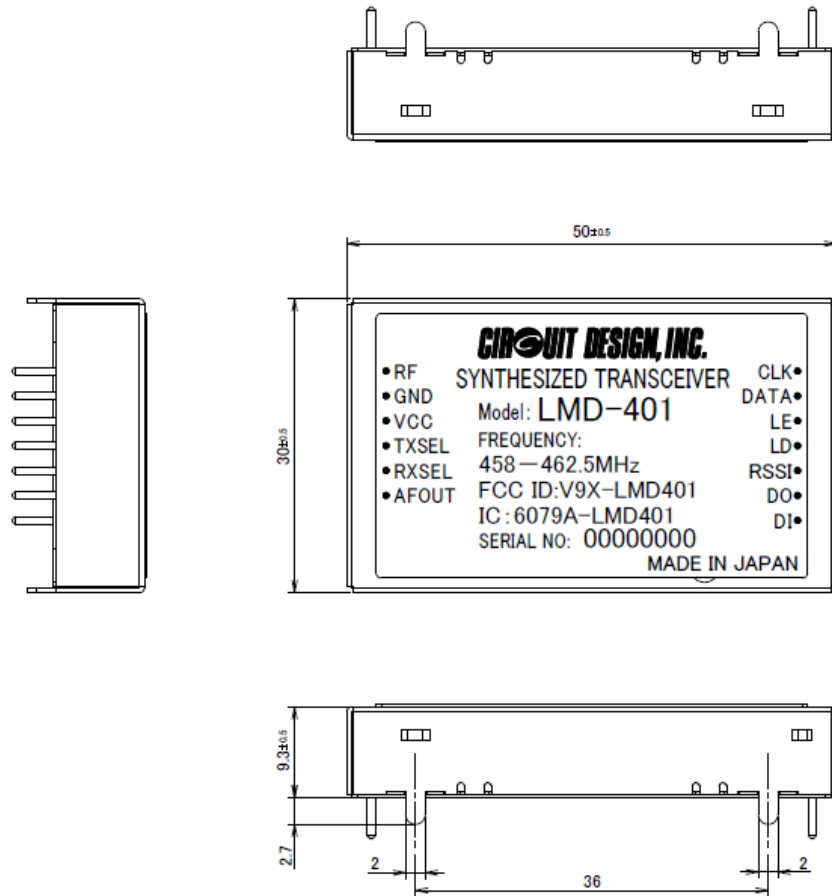

Reference hole position for PCB mounting (Top view)

PLL IC CONTROL

● **PLL IC control**

Figure 1

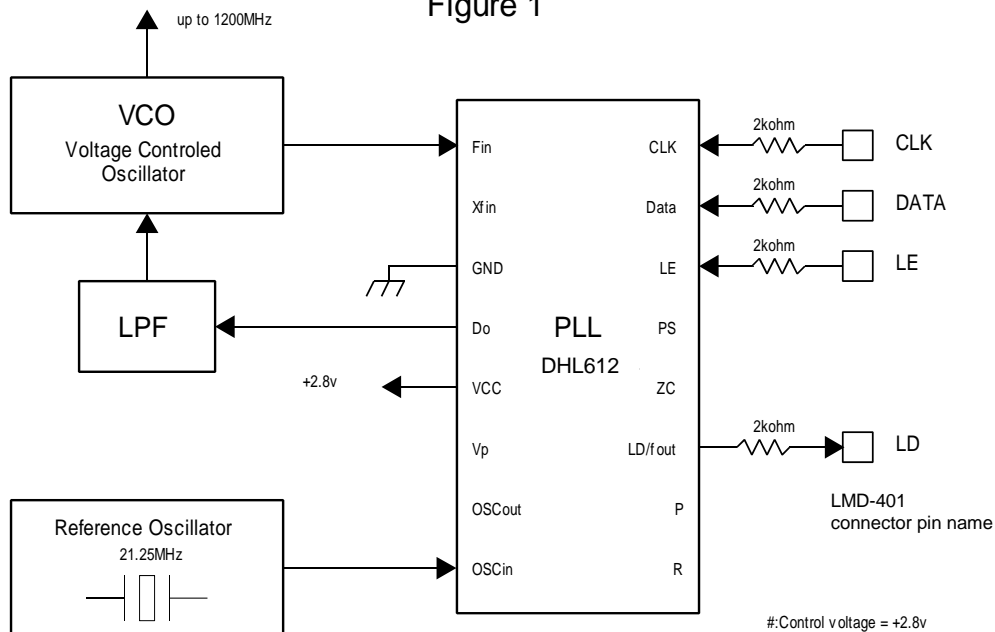

LMD-401 is equipped with an internal PLL frequency synthesizer as shown in Figure 1. The operation of the PLL circuit enables the VCO to oscillate at a stable frequency. Transmission frequency is set externally by the controlling IC. LMD-401 has control terminals (CLK, LE, DATA) for the PLL IC and the setting data is sent to the internal register serially via the data line. Also LMD-401 has a Lock Detect (LD) terminal that shows the lock status of the frequency. These signal lines are connected directly to the PLL IC through a 2 kΩ resistor.

The interface voltage of LMD-401 is 2.8 V, so the control voltage must be the same. LMD-401 comes equipped with a Intochips DHL612 PLL IC. Please refer to the manual of the PLL IC.

The following is a supplementary description related to operation with LMD-401. In this description, the same names and terminology as in the PLL IC manual are used, so please read the manual beforehand.

● How to calculate the setting values for the PLL register

The PLL IC manual shows that the PLL frequency setting value is obtained with the following equation.

$$f_{VCO} = \{(M \times P) + S\} \times f_{REF} / R \quad (S < P) \quad \text{--- Equation 1}$$

f_{VCO} : Output frequency of external VCO

M: Preset divide ratio of the prescaler (64 or 128)

P: Preset divide ratio of binary 11-bit programmable counter (3 to 2,047)

S: Preset divide ratio of binary 7-bit swallow counter (0 to 127)

f_{REF} : Output frequency of the reference frequency oscillator

R: Preset divide ratio of binary 14-bit programmable reference counter (3 to 16,383)

With LMD-401, there is an offset frequency (f_{OFFSET}) 21.7 MHz for the transmission RF channel frequency f_{CH} . Therefore the expected value of the frequency generated at VCO (f_{EXPECT}) is as below.

$$f_{VCO} = f_{EXPECT} = f_{CH} - f_{OFFSET} \quad \text{--- Equation 2}$$

The PLL internal circuit compares the phase to the oscillation frequency f_{VCO} . This phase comparison frequency (f_{COMP}) must be decided. f_{COMP} is made by dividing the frequency input to the PLL from the reference frequency oscillator by reference counter R. LMD-401 uses 21.25 MHz for the reference clock f_{REF} . f_{COMP} is one of 6.25 kHz, 12.5 kHz or 25 kHz.

The above equation 1 results in the following with $n = M \times P + S$, where “n” is the number for division.

$$f_{VCO} = n \times f_{COMP} \quad \text{--- Equation 3} \quad n = f_{VCO} / f_{COMP} \quad \text{--- Equation 4} \quad \text{note: } f_{COMP} = f_{REF} / R$$

Also, this PLL IC operates with the following R, P, S and M relational expressions.

$$R = f_{REF} / f_{COMP} \quad \text{--- Equation 5} \quad P = \text{INT}(n / M) \quad \text{--- Equation 6} \quad S = n - (M \times P) \quad \text{--- Equation 7}$$

INT: integer portion of a division.

As an example, the setting value of RF channel frequency f_{CH} 458.000 MHz can be calculated as below.

The constant values depend on the electronic circuits of LMD-401.

Conditions: Channel center frequency: $f_{CH} = 458.000$ MHz
 Constant: Offset frequency: $f_{OFFSET} = 21.7$ M
 Constant: Reference frequency: $f_{REF} = 21.25$ MHz
 Set 12.5 kHz for Phase comparison frequency and 64 for Prescaler value M

The frequency of VCO will be

$$f_{VCO} = f_{EXPECT} = f_{CH} - f_{OFFSET} = 458.000 - 21.7 = 436.300 \text{ MHz}$$

Dividing value “n” is derived from Equation 4

$$n = f_{VCO} / f_{COMP} = 436.300 \text{ MHz} / 12.5 \text{ kHz} = 34904$$

Value “R” of the reference counter is derived from Equation 5.

$$R = f_{REF} / f_{COMP} = 21.25 \text{ MHz} / 12.5 \text{ kHz} = 1700$$

Value “N” of the programmable counter is derived from Equation 6.

$$P = \text{INT}(n / M) = \text{INT}(34904 / 64) = 545$$

Value “A” of the swallow counter is derived from Equation 7.

$$S = n - (M \times P) = 34904 - 64 \times 545 = 24$$

The frequency of LMD-401 is locked at a center frequency f_{CH} by inputting the PLL setting values P, S and R obtained with the above equations as serial data. The above calculations are the same for the other frequencies.

Excel sheets that contain automatic calculations for the above equations can be found on our web site (www.circuitdesign.jp).

The result of the calculations is arranged as a table in the CPU ROM. The table is read by the channel change routine each time the channel is changed, and the data is sent to the PLL.

● **Method of serial data input to the PLL**

After the RF channel table plan is decided, the data needs to be allocated to the ROM table and read from there or calculated with the software.

Together with this setting data, operation bits that decide operation of the PLL must be sent to the PLL.

The operation bits for setting the PLL are as follows. These values are placed at the head of the reference counter value and are sent to the PLL.

1. CS: Charge pump current select bit
 CS = 0 +/-1.5 mA select VCO is optimized to +/-1.5 mA
2. LDS: LD/fout output setting bit
 LDS = 0 LD select Hardware is set to LD output
3. FC: Phase control bit for the phase comparator
 FC = 1 Hardware operates at this phase

Figure 2

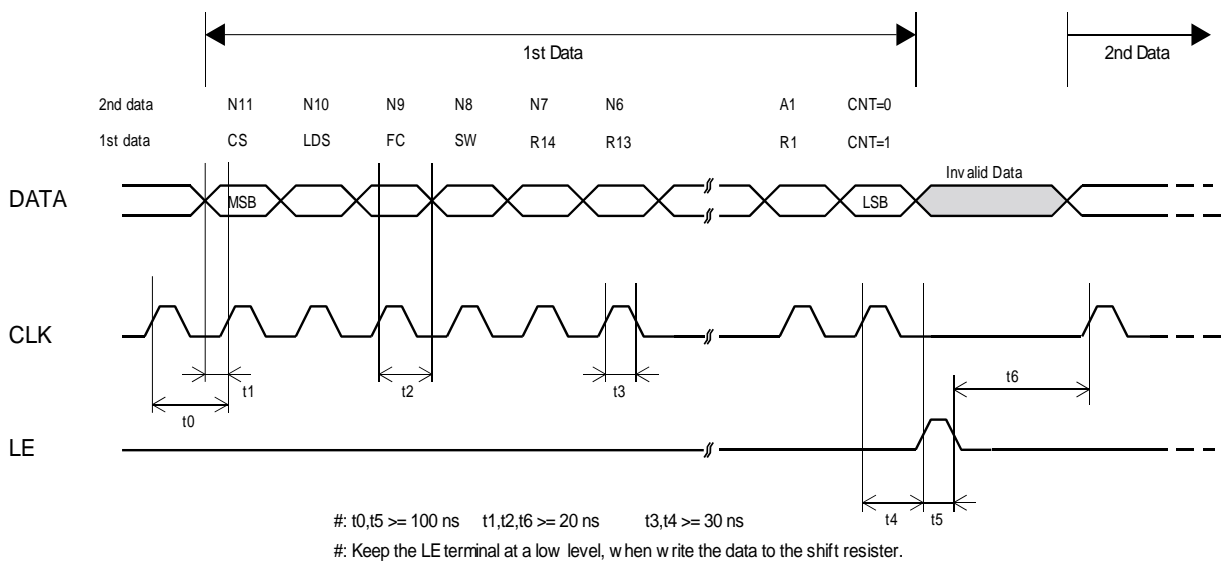

The PLL IC, which operates as shown in the block diagram in the manual, shifts the data to the 19-bit shift register and then transfers it to the respective latch (counter, register) by judging the CNT control bit value input at the end.

1. CLK [Clock]: Data is shifted into the shift register on the rising edge of this clock.
2. LE [Load Enable]: Data in the 19-bit shift register is transferred to respective latches on the rising edge of the clock. The data is transferred to a latch according to the control bit CNT value.
3. Data [Serial Data]: You can perform either reference counter setup or programmable counter setup first.

TIMING CHART

Control timing in a typical application is shown in Figure 3.

Initial setting of the port connected to the radio module is performed when power is supplied by the CPU and reset is completed. MOS-FET for supply voltage control of the radio module, RXSEL and TXSEL are set to inactive to avoid unwanted emissions. The power supply of the radio module is then turned on. When the radio module is turned on, the PLL internal resistor is not yet set and the peripheral VCO circuit is unstable. Therefore data transmission and reception is possible 40 ms after the setting data is sent to the PLL at the first change of channel, however from the second change of channel, the circuit stabilizes within 20 ms and is able to handle the data.

Changing channels must be carried out in the receive mode. If switching is performed in transmission mode, unwanted emission occurs.

If the module is switched to the receive mode when operating in the same channel, (a new PLL setting is not necessary) it can receive data within 5 ms of switching^{*1}. For data transmission, if the RF channel to be used for transmission is set while still in receiving mode, data can be sent at 5 ms after the radio module is switched from reception to transmission^{*2}.

Check that the Lock Detect signal is "high" 20 ms after the channel is changed. In some cases the Lock Detect signal becomes unstable before the lock is correctly detected, so it is necessary to note if processing of the signal is interrupted. It is recommended to observe the actual waveform before writing the process program.

^{*1} DC offset may occur due to frequency drift caused by ambient temperature change. Under conditions below -10 °C, 10 to 20 ms delay of DO output is estimated. The customer is urged to verify operation at low temperature and optimize the timing.

^{*2} Sending '10101.....' preamble just after switching to transmission mode enables smoother operation of the binarization circuit of the receiver. Preamble length: 15 ms (Typical) at -20 to + 65°C

Figure 3: Timing diagram for LMD-401

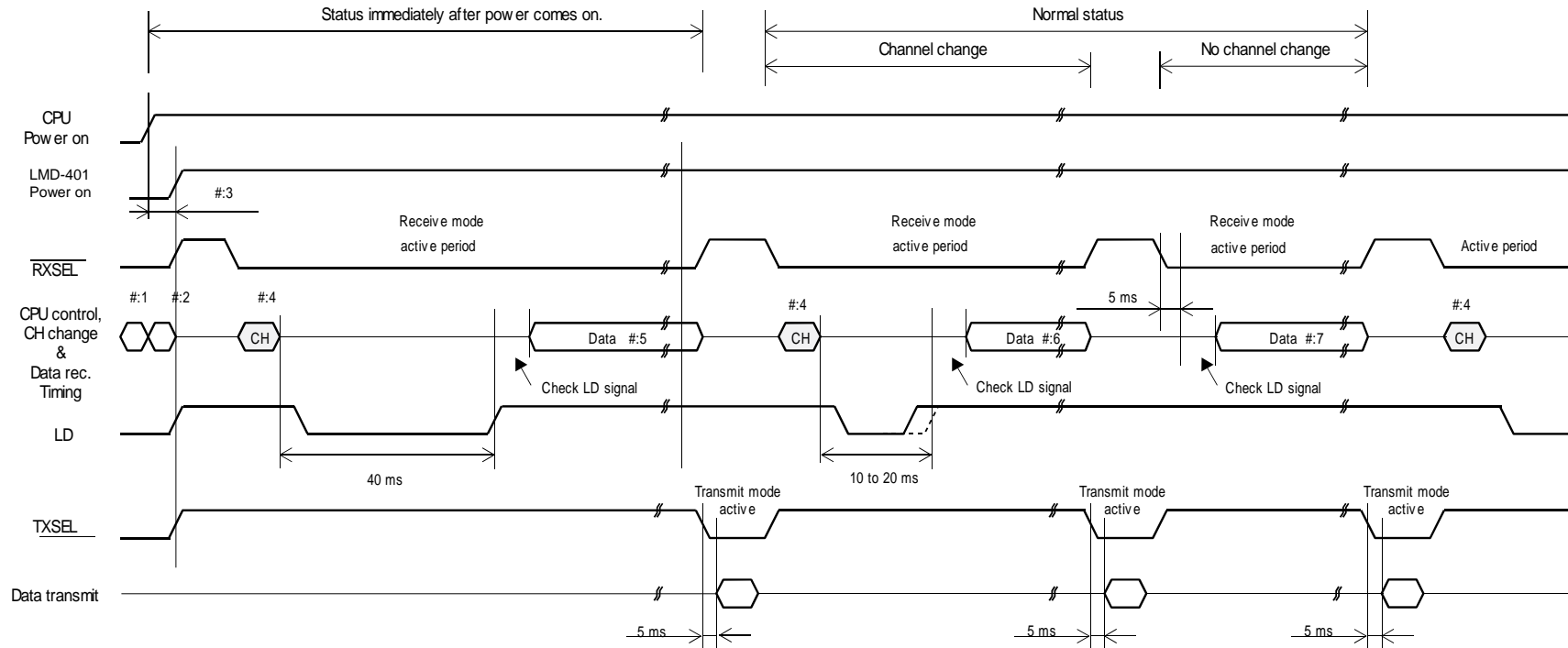

- #:1 Reset control CPU
- #:2 Initialize the port connected to the module.
- #:3 Supply power to the module after initializing CPU.
- #:4 RFchannel change must be performed in receiving mode.

- #:5 40 ms later, the receiver can receive the data after changing the channel..
- #:6 10 to 20 ms later, the receiver can receive the data after changing the channel.
- #:7 5 ms later, the data can be received if the RF channel is not changed.

PLL FREQUENCY SETTING DATA REFERENCE

Example : Setting from 458.000 MHz to 458.6125 MHz

Parameter name	Value
Phase Comparing Frequency F_{COMP} [kHz]	12.5
Start Channel Frequency F_{CH} [MHz]	458.000
Channel Step Frequency [kHz]	12.5
Number of Channel	50
Prescaler M	64

: For data input
 : Result of calculation
 : Fixed value

Parameter name	Value
Reference Frequency F_{REF} [MHz]	21.25
Offset Frequency F_{OFFSET} [MHz]	21.7

Parameter name	Value
Reference Counter R	1700
Programmable Counter P Min. Value	545
Programmable Counter P Max. Value	546
Swallow Counter S Min. Value	0
Swallow Counter S Max. Value	63

Channel Frequency F_{CH} (MHz)	Expect Frequency F_{EXPECT} (MHz)	Lock Frequency F_{VCO} (MHz)	Number of Division n	Programable Counter P	Swallow Counter S
458.0000	436.3000	436.3000	34904	545	24
458.0125	436.3125	436.3125	34905	545	25
458.0250	436.3250	436.3250	34906	545	26
458.0375	436.3375	436.3375	34907	545	27
458.0500	436.3500	436.3500	34908	545	28
458.0625	436.3625	436.3625	34909	545	29
458.0750	436.3750	436.3750	34910	545	30
458.0875	436.3875	436.3875	34911	545	31
458.1000	436.4000	436.4000	34912	545	32
458.1125	436.4125	436.4125	34913	545	33
458.1250	436.4250	436.4250	34914	545	34
458.1375	436.4375	436.4375	34915	545	35
458.1500	436.4500	436.4500	34916	545	36
458.1625	436.4625	436.4625	34917	545	37
458.1750	436.4750	436.4750	34918	545	38
458.1875	436.4875	436.4875	34919	545	39
458.2000	436.5000	436.5000	34920	545	40
458.2125	436.5125	436.5125	34921	545	41
458.2250	436.5250	436.5250	34922	545	42
458.2375	436.5375	436.5375	34923	545	43
458.2500	436.5500	436.5500	34924	545	44
458.2625	436.5625	436.5625	34925	545	45
458.2750	436.5750	436.5750	34926	545	46
458.2875	436.5875	436.5875	34927	545	47
458.3000	436.6000	436.6000	34928	545	48
458.3125	436.6125	436.6125	34929	545	49
458.3250	436.6250	436.6250	34930	545	50
458.3375	436.6375	436.6375	34931	545	51
458.3500	436.6500	436.6500	34932	545	52

458.3625	436.6625	436.6625	34933	545	53
458.3750	436.6750	436.6750	34934	545	54
458.3875	436.6875	436.6875	34935	545	55
458.4000	436.7000	436.7000	34936	545	56
458.4125	436.7125	436.7125	34937	545	57
458.4250	436.7250	436.7250	34938	545	58
458.4375	436.7375	436.7375	34939	545	59
458.4500	436.7500	436.7500	34940	545	60
458.4625	436.7625	436.7625	34941	545	61
458.4750	436.7750	436.7750	34942	545	62
458.4875	436.7875	436.7875	34943	545	63
458.5000	436.8000	436.8000	34944	546	0
458.5125	436.8125	436.8125	34945	546	1
458.5250	436.8250	436.8250	34946	546	2
458.5375	436.8375	436.8375	34947	546	3
458.5500	436.8500	436.8500	34948	546	4
458.5625	436.8625	436.8625	34949	546	5
458.5750	436.8750	436.8750	34950	546	6
458.5875	436.8875	436.8875	34951	546	7
458.6000	436.9000	436.9000	34952	546	8
458.6125	436.9125	436.9125	34953	546	9

Excel sheets that contain automatic calculations for the above equations can be found on our web site (www.circuitdesign.jp).

Regulatory compliance information

Regulatory Statement for FCC

The LMD-401 complies with the FCC Part 90.

Labelling:

The LMD-401 is labeled as below.

FCC ID: V9X-LMD401

The proposed FCC ID label format is to be placed on the module. If FCC ID is not visible when the module is installed into the system, "Contains FCC ID: V9X-LMD401" shall be placed on the outside of final host system.

Exposure to radio frequency radiation

This device complies with FCC radiation exposure limits set forth for an uncontrolled environment and meets the FCC radio frequency (RF) Exposure Guidelines as this equipment has very low power levels of RF energy.

Note:

The LMD-400-R has been tested and found to comply with the limits for a Class B digital device, pursuant to Part 15 of the FCC Rules. These limits are designed to provide reasonable protection against harmful interference in a commercial installation. This equipment generates, uses, and can radiate radio frequency energy and, if not installed and used in accordance with the instructions, may cause harmful interference to radio communications. However, there is no guarantee that interference will not occur in a particular installation. If this equipment does cause harmful interference to radio or television reception, which can be determined by turning the equipment off and on, the user is encouraged to try to correct the interference by one or more of the following measures:

- Reorient or relocate the receiving antenna.
- Keep water and moisture out of all antenna and radio fittings.
- Check all antenna connections – any imbalance in coax cable can cause radio interference and receive / transmit problems.

Caution:

The LMD-401 is only authorized for FCC Part 90 and the host product manufacturer is responsible for compliance to any other FCC rules that apply to the host product.

The final host product will need to be reassessed with the LMD-401 installed for compliance to FCC Part 15 Subpart B on host manufacturer's responsibility, if applicable.

Changes or modifications not expressly approved by the party responsible for compliance could void the user's authority to operate the device.

This device must not be co-located or operated in conjunction with any other antenna or transmitter.

This device is supposed to be operated under 90.267. However, there are some limitations as below:

90.267(e)(1) Group C frequencies are available for voice and non voice operations on a co-primary basis. Only mobile operations will be authorized on Group C frequencies. Stations may operate at fixed locations for a temporary period of time. No stations operating at a permanent fixed location will be authorized on Group C frequencies.

90.267(f)(2) Group D frequencies subject to §90.35(c)(63) are limited to central station alarm use within the urban areas described in §90.35(c)(63). Outside the urban areas described in 90.35(c)(63), Group D frequencies subject to §90.35(c)(63) are available for general Industrial/Business use on a coordinated basis, pursuant to §§90.35(b)(2) and 90.175(b).

90.267(f)(3) Group D frequencies subject to §90.35(c)(66) are limited to central station alarm use nationwide.

90.267(h)(5) Continuous carrier operations are prohibited on these frequencies.

Licensing of end-use products

LMD-401 holds equipment authorization for transmitting equipment under Title 47 of the Code of Federal Regulations Part 90. (FCC Identifier: V9X-LMD401)

This shall be the only guarantee of Circuit Design Inc for compliance with FCC regulations. Those who integrate LMD-401 in a system and operate the radio system in the United States are required to apply for a user station license before the equipment can be operated. Application for the station license in Part 90 may be required to be submitted to a certified frequency coordinator for frequency coordination, then the FCC licensing bureau issues a license for equipment users/stations. As local frequency management issues are involved in licensing, Circuit Design Inc shall not be held liable for failure in obtaining the station license. Circuit Design Inc recommends users to contact a certified frequency coordinator in the region in advance to confirm whether or not a license can be granted.

Regulatory Statement for Industry Canada

The LMD-401 complies with the RSS-119.

Caution:

Any changes or modifications not expressly approved by the party responsible for product compliance could void the user's authority to operate the equipment.

Labelling:

The LMD-401 is labeled as below.

IC Number: 6079A-LMD401

The proposed IC Number label format is to be placed on the module. If IC Number is not visible when the module is installed into the system, "Contains IC: 6079A-LMD401" shall be placed on the outside of final host system.

Antenna:

This radio transmitter (6079A-LMD401) has been approved by Innovation, Science and Economic Development Canada to operate with the antenna types listed below, with the maximum permissible gain indicated. Antenna types not included in this list that have a gain greater than the maximum gain indicated for any type listed are strictly prohibited for use with this device.

Antenna type: Whip antenna (ANT-LEA-01-R/ANT-RIG-01-R)

Gain: 1.83 dBi

Impedance: 50 Ω

Le présent émetteur radio (6079A-LMD401) a été approuvé par Innovation, Sciences et Développement économique Canada pour fonctionner avec les types d'antenne énumérés ci-dessous et ayant un gain admissible maximal. Les types d'antenne non inclus dans cette liste, et dont le gain est supérieur au gain maximal indiqué pour tout type figurant sur la liste, sont strictement interdits pour l'exploitation de l'émetteur.

Type d'antenne: Whip antenna (ANT-LEA-01-R/ANT-RIG-01-R)

Gain: 1.83 dBi

l'impédance: 50 Ω

Caution: Exposure to Radio Frequency Radiation:

This equipment complies with ISED radiation exposure limits set forth for an uncontrolled environment and meets RSS-102 of the ISED radio frequency (RF) Exposure rules as this equipment has very low levels of RF energy.

Cet équipement est conforme aux limites d'exposition aux rayonnements énoncées pour un environnement non contrôlé et respecte les règles d'exposition aux fréquences radioélectriques (RF) CNR-102 de l'ISDE puisque cet appareil a une niveau tres bas d'energie RF.

Licensing of end-use products

LMD-401 MHz holds equipment authorization for transmitting equipment under RSS-119 (IC Number: 6079A-LMD401).

This shall be the only guarantee of Circuit Design Inc for compliance with Innovation, Science and Economic Development Canada regulations. Those who integrate LMD-401 in a system and operate the radio system in Canada are required to apply for a user station license before the equipment can be operated.

Application for the station license in RSS-119 may be required to be submitted to a certified frequency coordinator for frequency coordination, then the Industry Canada licensing bureau issues a license for equipment users/stations. As local frequency management issues are involved in licensing, Circuit Design Inc shall not be held liable for failure in obtaining the station license. Circuit Design Inc recommends users to contact a certified frequency coordinator in the region in advance to confirm whether or not a license can be granted.

Important notice

- Customers are advised to consult with Circuit Design sales representatives before ordering. Circuit Design believes the provided information is accurate and reliable. However, Circuit Design reserves the right to make changes to this product without notice.
- Circuit Design products are neither designed nor intended for use in life support applications where malfunction can reasonably be expected to result in significant personal injury to the user. Any use of Circuit Design products in such safety-critical applications is understood to be fully at the risk of the customer and the customer must fully indemnify Circuit Design, Inc for any damages resulting from any improper use.
- As the radio module communicates using electronic radio waves, there are cases where transmission will be temporarily cut off due to the surrounding environment and method of usage. The manufacturer is exempt from all responsibility relating to resulting harm to personnel or equipment and other secondary damage.
- The manufacturer is exempt from all responsibility relating to secondary damage resulting from the operation, performance and reliability of equipment connected to the radio module.

Copyright

- All rights in this operation guide are owned by Circuit Design, Inc. No part of this document may be copied or distributed in part or in whole without the prior written consent of Circuit Design, Inc.

Cautions

- As the radio module communicates using electronic radio waves, there are cases where transmission will be temporarily cut off due to the surrounding environment and method of usage. The manufacturer is exempt from all responsibility relating to resulting harm to personnel or equipment and other secondary damage.
- Do not use the equipment within the vicinity of devices that may malfunction as a result of electronic radio waves from the radio module.
- The manufacturer is exempt from all responsibility relating to secondary damage resulting from the operation, performance and reliability of equipment connected to the radio module.
- Communication performance will be affected by the surrounding environment, so communication tests should be carried out before actual use.
- Ensure that the power supply for the radio module is within the specified rating. Short circuits and reverse connections may result in overheating and damage and must be avoided at all costs.
- Ensure that the power supply has been switched off before attempting any wiring work.
- The case is connected to the GND terminal of the internal circuit, so do not make contact between the '+' side of the power supply terminal and the case.
- When batteries are used as the power source, avoid short circuits, recharging, dismantling, and pressure. Failure to observe this caution may result in the outbreak of fire, overheating and damage to the equipment. Remove the batteries when the equipment is not to be used for a long period of time. Failure to observe this caution may result in battery leaks and damage to the equipment.
- Do not use this equipment in vehicles with the windows closed, in locations where it is subject to direct sunlight, or in locations with extremely high humidity.
- The radio module is neither waterproof nor splash proof. Ensure that it is not splashed with soot or water. Do not use the equipment if water or other foreign matter has entered the case.
- Do not drop the radio module or otherwise subject it to strong shocks.
- Do not subject the equipment to condensation (including moving it from cold locations to locations with a significant increase in temperature.)
- Do not use the equipment in locations where it is likely to be affected by acid, alkalis, organic agents or corrosive gas.
- Do not bend or break the antenna. Metallic objects placed in the vicinity of the antenna will have a great effect on communication performance. As far as possible, ensure that the equipment is placed well away from metallic objects.
- The GND for the radio module will also affect communication performance. If possible, ensure that the case GND and the circuit GND are connected to a large GND pattern.

Warnings

- Do not take a part or modify the equipment.
- Do not remove the product label (the label attached to the upper surface of the module.) Using a module from which the label has been removed is prohibited.

REVISION HISTORY

Version	Date	Description	Remark
1.0	May. 2020		