

Embedded low power radio modem

# SLR-434M

*Smart RF modem*



## Operation Guide

Version 2.0 (Mar. 2020)

---

### Circuit Design, Inc.

7557-1 Hotaka, Azumino, Nagano, Japan

Tel: 0263-82-1024

Fax: 0263-82-1016

e-mail: [info@circuitdesign.jp](mailto:info@circuitdesign.jp)

<http://www.circuitdesign.jp>

## Contents

1. OVERVIEW .....	3
2. FEATURES AND APPLICATIONS.....	3
3. SPECIFICATIONS .....	4
4. PART NAMES AND FUNCTIONS .....	5
5. CONNECTION EXAMPLES FOR DIO TERMINALS .....	8
6. APPEARANCE.....	9
7. COMMUNICATION FREQUENCY TABLE .....	10
8. UART PORT COMMUNICATION SETTINGS.....	11
9. SERIAL COMMUNICATION COMMANDS.....	12

## 1. Overview

The SLR-434M smart RF modem is a compact, easy to use, wireless modular RF modem for embedding in other equipment.

In addition to conventional FSK mode communication, it also comes with a LoRa® mode\* for ultra long distance communication and low bit rate. With its superior receive sensitivity using LoRa® modulation, it achieves both specific low power output, with a line of sight communication range of more than 10 kilometers.

Connection to an external microcomputer or a PC via a UART and our proprietary command system fostered in the industry make it possible for you to easily transmit/receive data.

Also you can control up to 8 contacts.

\*The SLR-434M contains a Semtech's LoRa® wireless RF IC.

The LoRa® Mark and LoRa Logo are trademarks of Semtech Corporation.

## 2. Features and applications

### Features

- RED compliant (Plan)
- Ultra long distance communication using the LoRa® mode
- Enhanced resistant to city noise and longer range compared with our earlier products
- Select between FSK mode and LoRa® mode
- UART interface
- Control of 8 contacts
- Low power consumption enables battery powered operation
- Compact size

### Applications

- Data transfer inside buildings, air conditioning control
- Debris avalanche monitoring for debris barriers
- Water level monitoring for river dams, opening and closing of water gates
- Paddy field temperature and water level monitoring
- Monitoring and control of greenhouse temperature and humidity
- Transmission of sensor data from underground or inside manholes
- Measurement and observation of the state of tunnels and bridges
- Monitoring the state of electric fences
- Monitoring the state of animal traps
- Other IoT applications

### 3. Specifications

\*All values are when the antenna connector is the 50 Ω terminal.

\*Unless otherwise indicated, specified values are at a temperature of 25 °C ± 5 °C.

Item	Specification
Applicable standard	EN 300 220
Frequency channels	433.075 MHz to 434.7750 MHz (12.5 KHz step, 137 channels)
Frequency deviation	± 2 ppm or less
Antenna power	10 mW or less
Communication method	Half-duplex or one-way
Radio wave format	F1D
Modulation*1	LoRa® or Binary FSK
Radio communication speed	15 to 245 bps (Real speed using LoRa® modulation, Depends on the spreading factor) 4800 bps (FSK)
Receiver spurious radiation	-57 dBm or less
Receive sensitivity*2	-133 dBm (LoRa® mode 128 chip), -115 dBm or less (FSK mode), PER 1% with the user data of 45 bytes or less
Carrier sensing threshold	-80 dBm (LoRa® mode)
Operating temperature range	-30 to +70°C
Storage temperature range	-30 to +80°C
Recommended operating voltage range	3.5 to 5.0 V
Warranted operating voltage range	3.3 to 5.5 V
Operating current	Tx: 29 mA (Typ) Rx: 17 mA (Typ) (Supply power = 5 V)
Antenna provided	1/4λ whip antenna (L=170 mm, gain 2.14 dBi or less)
Antenna connector	SMA
Interface	UART port
External dimensions	40 × 29 × 6.2 mm (±0.4) (Not including the antenna and projections)
Weight	13 g
Soldering conditions	Hand soldering Soldering iron temp.: 350°C within 3 seconds

Note:

\*1: When using the LoRa® mode and moving around, the impact of the Doppler effect may make communication impossible.

\*2: Receive sensitivity performance is affected by the power supply and surrounding noise levels (floor noise level). The approximate minimum level at which reception is possible is noise level +10 dB for FSK and -10 dB for LoRa®. (Example: When the floor noise level is -110 dBm, reception is possible with FSK to about -100 dBm and with LoRa® to about -120 dBm). You can check the floor noise level with the @RA command and the evaluation application (air monitor).

**4. Part Names and Functions**

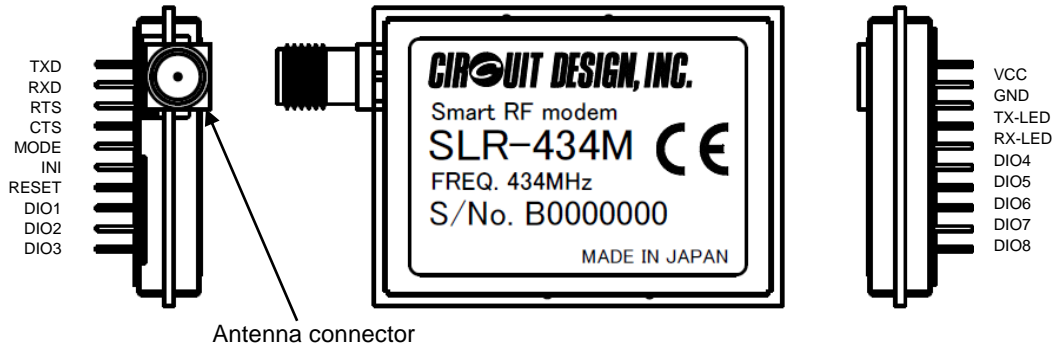

Names and functions	I/O	Content		Internal equivalent circuit
TXD	O	A UART serial communication terminal. It sets the device and transmits and receives data.	Serial data Transmitter	
RXD	I	(Communication conditions: 19.2 kbps, Bits =8, Parity = none, Stop = 1)	Serial data Receiver	
RTS	O	The UART control terminal. When RTS = "Hi", do not input data.	Hardware flow control output terminal	
CTS	I	The UART control terminal. When CTS = "Hi", data is not output. (Set it to "Lo".)	Hardware flow control input terminal	
MODE	I	(Reserved) Nothing should be connected to this terminal.		

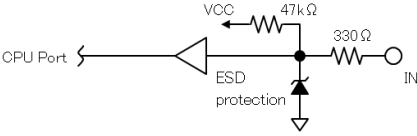
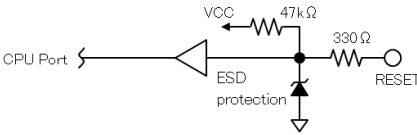
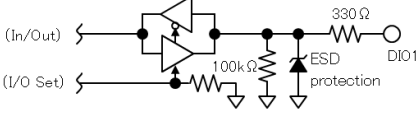
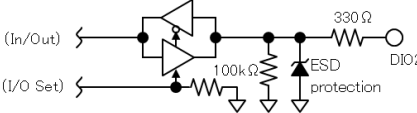
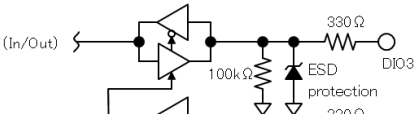
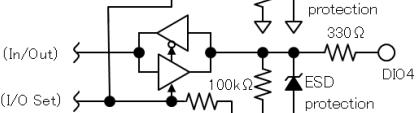
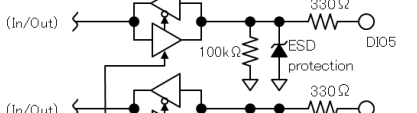
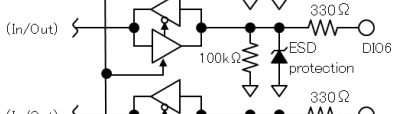
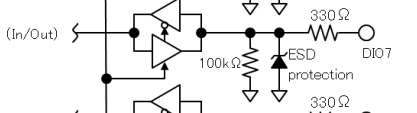
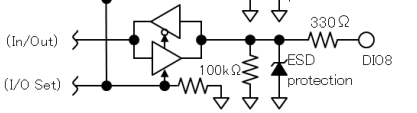
<p>INI</p>	<p>I</p>	<p>With the power on, setting this terminal to "Lo" for 3 s or more resets and restarts the unit, and if the wireless communication mode is binary mode, it enters the command mode. For details about the wireless communication mode, refer to the operation guide "SLR-434 Serial Communication".</p> <p>Normally, when set to the wireless communication mode, the settings are saved automatically and are used as the initial values next time the power is switched on. However, after setting the binary mode, it is not possible to receive commands, therefore it is necessary to perform this task to return to the command mode. When this task is performed, "LORA CMD MODE" or "FSK CMD MODE" is output from the TXD terminal after the device restarts.</p> <p>After reset and restart, the device is initialized to the setting value saved by adding 'W' to commands such as chip number, frequency channel.</p>	
<p>RESET</p>	<p>I</p>	<p>The CPU reset terminal (Lo active). After reset and restart, the device is initialized to the setting value saved by adding 'W' to commands such as chip number, frequency channel.</p>	
<p>DIO1</p>	<p>I/O</p>	<p>Digital I/O pin 1. Input/output settings can be made with commands.</p>	
<p>DIO2</p>	<p>I/O</p>	<p>Digital I/O pin 2. Input/output settings can be made with commands.</p>	
<p>DIO3</p>	<p>I/O</p>	<p>Digital I/O pin 3.</p>	
<p>DIO4</p>	<p>I/O</p>	<p>Digital I/O pin 4.</p>	
<p>DIO5</p>	<p>I/O</p>	<p>Digital I/O pin 5.</p>	
<p>DIO6</p>	<p>I/O</p>	<p>Digital I/O pin 6.</p>	
<p>DIO7</p>	<p>I/O</p>	<p>Digital I/O pin 7.</p>	
<p>DIO8</p>	<p>I/O</p>	<p>Digital I/O pin 8.</p>	
<p>Input/output settings can be made with commands. DIO3 and DIO4 cannot be set individually.</p> <p>Input/output settings can be made with commands. DIO5 to DIO8 cannot be set individually.</p>			

<p>RX-LED</p>	<p>O</p>	<p>The reception monitor LED connection terminal (Lo Active). When a radio wave communication signal is received, this terminal changes to "Lo" for about 0.1 s.</p>	
<p>TX-LED</p>	<p>O</p>	<p>The transmission monitor LED connection terminal (Lo Active). When a radio wave communication signal is sent, this terminal changes to "Lo".</p>	
<p>GND</p>		<p>The ground terminal.</p>	
<p>VCC</p>		<p>The power supply terminal. Connect to a stabilized DC+3.3 V to +5.5 V power supply.</p>	
<p>Antenna Connector</p>	<p>I/O</p>	<p>The connection pin for the antenna.</p>	

※ The voltage range of the output terminal is 0 to Vcc [V].  
Use the input terminal within the range Hi = 2.0 to Vcc [V], Lo = 0 to 0.6 [V]

## 5. Connection examples for DIO terminals

### <When using the DIO terminals as input ports and connecting switches>

The DIO terminals are internally pulled-down and can be operated by connecting switches between the DIO terminals and the VCC terminal as shown below (SW1 & SW2). The SW3 in the circuit below shows an example of connecting a switch to the GND side with the signal level inverted via a transistor.

Using long wiring between the DIO terminal and the switch may cause malfunction due to noise. In that case, take measures such as externally pulling down with a resistor of a few to tens of kΩ.

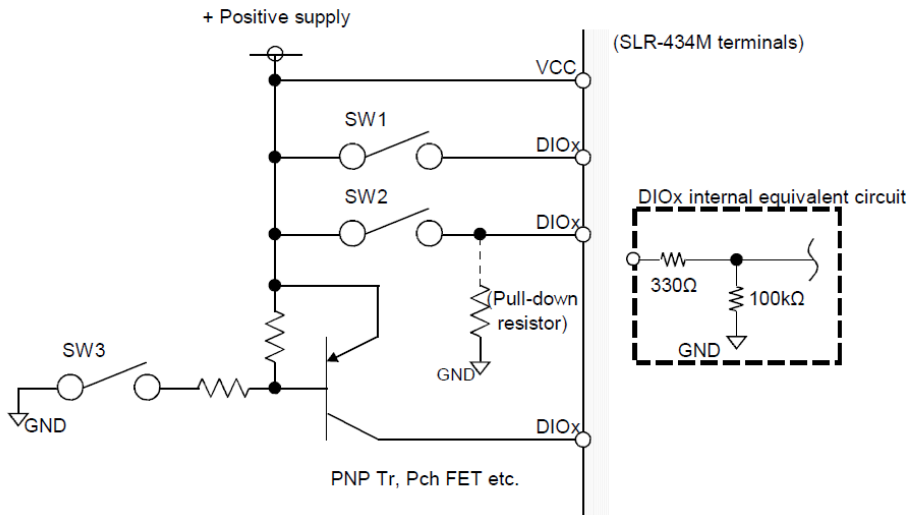

### <When using the DIO terminals as output ports and connecting loads>

The output current at the DIO terminal should be 5 mA or less.

Pay attention to the voltage drop due to the 330 Ω resistor inside the SLR-434M (see the equivalent circuit above.)

A load of a few mA, such as LED, can be directly driven as below.

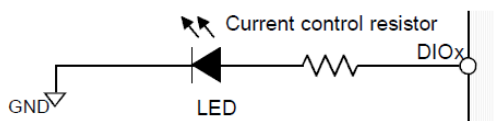

Connecting a transistor or FET

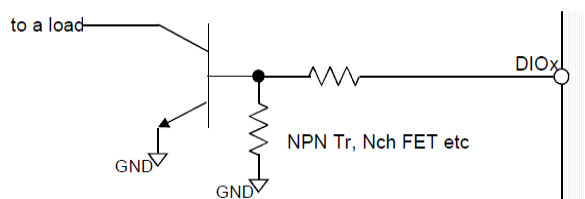

Connecting a Photo Tr or PhotoMOS relay

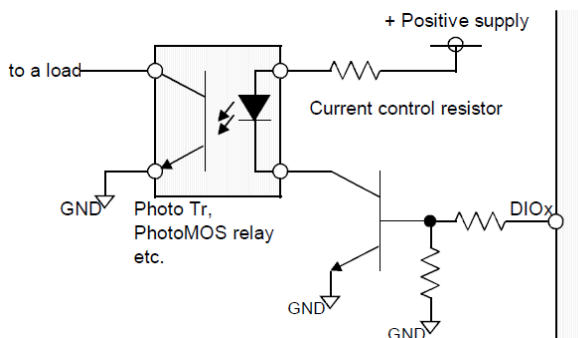

Connecting a relay

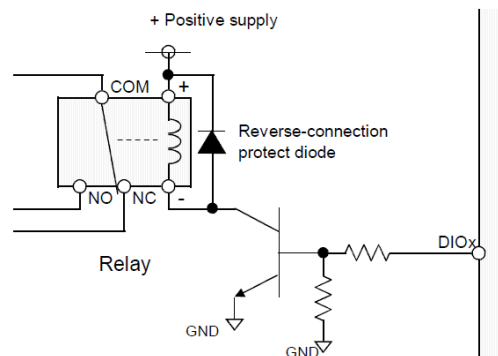



**6. Appearance**

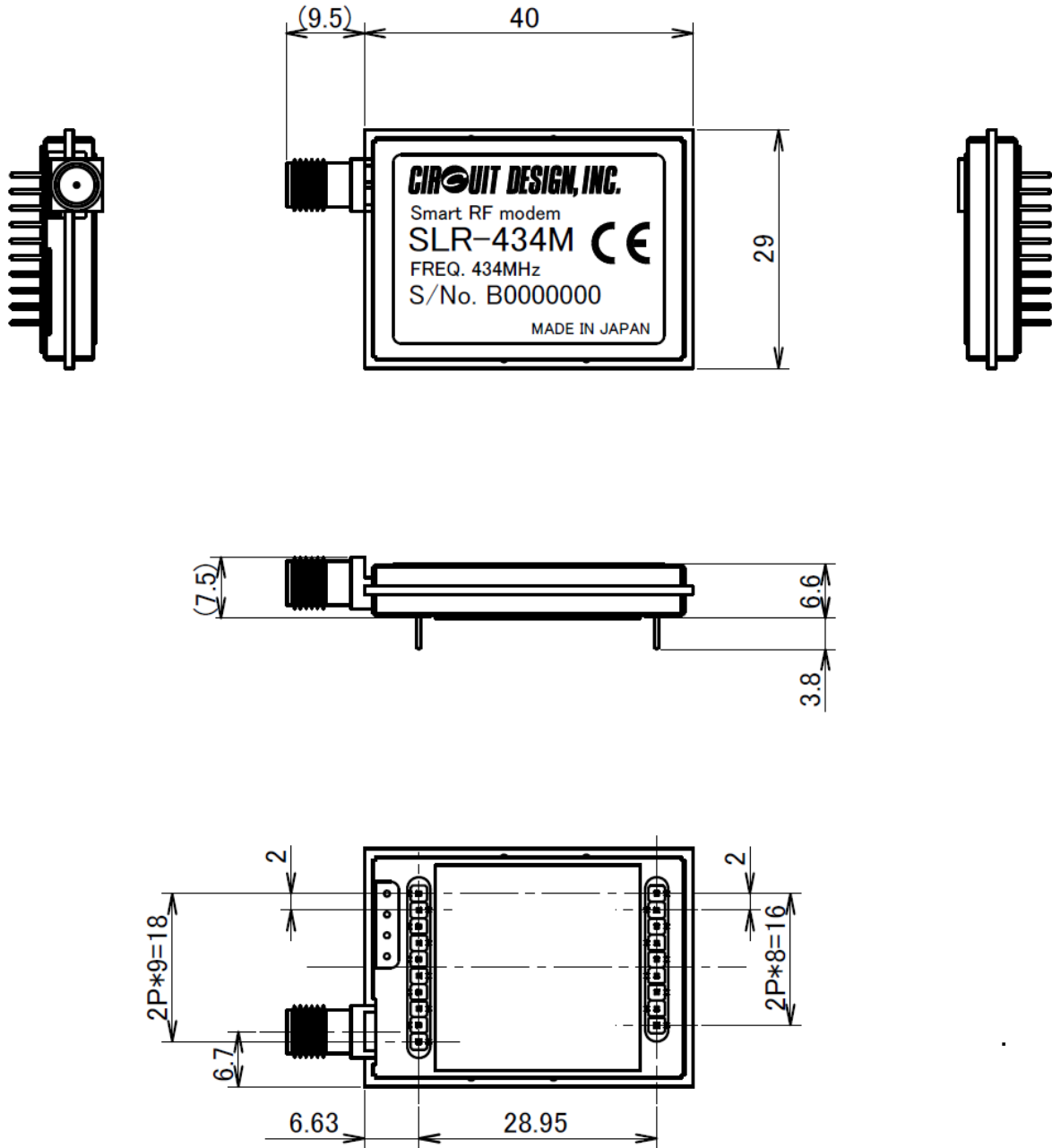

Note: When designing circuit boards, take care to ensure space for the SMA connector dimensions and screw fixture for connecting the antenna. (If the underside of the connector is also the surface of the substrate, provide a notch or the like)

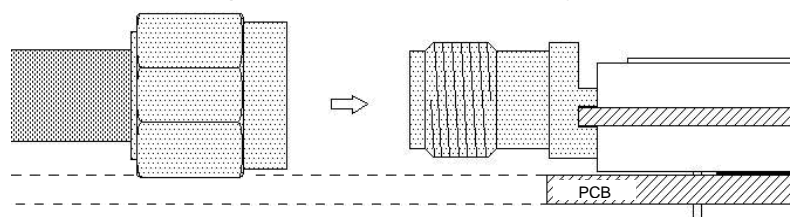

## 7. Communication frequency table

The frequencies used for radio communication are the 137 channels in the 434 MHz band shown in the table below.

Channel		Frequency (MHz)	Channel		Frequency (MHz)	Channel		Frequency (MHz)
NO.	HEX		NO.	HEX		NO.	HEX	
0	00	433.0750	34	22	433.5000	68	44	433.9250
1	01	433.0875	35	23	433.5125	69	45	433.9375
2	02	433.1000	36	24	433.5250	70	46	433.9500
3	03	433.1125	37	25	433.5375	71	47	433.9625
4	04	433.1250	38	26	433.5500	72	48	433.9750
5	05	433.1375	39	27	433.5625	73	49	433.9875
6	06	433.1500	40	28	433.5750	<b>74</b>	<b>4A</b>	<b>434.0000</b>
7	07	433.1625	41	29	433.5875	75	4B	434.0125
8	08	433.1750	42	2A	433.6000	76	4C	434.0250
9	09	433.1875	43	2B	433.6125	77	4D	434.0375
10	0A	433.2000	44	2C	433.6250	78	4E	434.0500
11	0B	433.2125	45	2D	433.6375	79	4F	434.0625
12	0C	433.2250	46	2E	433.6500	80	50	434.0750
13	0D	433.2375	47	2F	433.6625	81	51	434.0875
14	0E	433.2500	48	30	433.6750	82	52	434.1000
15	0F	433.2625	49	31	433.6875	83	53	434.1125
16	10	433.2750	50	32	433.7000	84	54	434.1250
17	11	433.2875	51	33	433.7125	85	55	434.1375
18	12	433.3000	52	34	433.7250	86	56	434.1500
19	13	433.3125	53	35	433.7375	87	57	434.1625
20	14	433.3250	54	36	433.7500	88	58	434.1750
21	15	433.3375	55	37	433.7625	89	59	434.1875
22	16	433.3500	56	38	433.7750	90	5A	434.2000
23	17	433.3625	57	39	433.7875	91	5B	434.2125
24	18	433.3750	58	3A	433.8000	92	5C	434.2250
25	19	433.3875	59	3B	433.8125	93	5D	434.2375
26	1A	433.4000	60	3C	433.8250	94	5E	434.2500
27	1B	433.4125	61	3D	433.8375	95	5F	434.2625
28	1C	433.4250	62	3E	433.8500	96	60	434.2750
29	1D	433.4375	63	3F	433.8625	97	61	434.2875
30	1E	433.4500	64	40	433.8750	98	62	434.3000
31	1F	433.4625	65	41	433.8875	99	63	434.3125
32	20	433.4750	66	42	433.9000	100	64	434.3250
33	21	433.4875	67	43	433.9125	101	65	434.3375

Channel		Frequency (MHz)	Channel		Frequency (MHz)	Channel		Frequency (MHz)
NO.	HEX		NO.	HEX		NO.	HEX	
102	66	434.3500	114	72	434.5000	126	7E	434.6500
103	67	434.3625	115	73	434.5125	127	7F	434.6625
104	68	434.3750	116	74	434.5250	128	80	434.6750
105	69	434.3875	117	75	434.5375	129	81	434.6875
106	6A	434.4000	118	76	434.5500	130	82	434.7000
107	6B	434.4125	119	77	434.5625	131	83	434.7125
108	6C	434.4250	120	78	434.5750	132	84	434.7250
109	6D	434.4375	121	79	434.5875	133	85	434.7375
110	6E	434.4500	122	7A	434.6000	134	86	434.7500
111	6F	434.4625	123	7B	434.6125	135	87	434.7625
112	70	434.4750	124	7C	434.6250	136	88	434.7750
113	71	434.4875	125	7D	434.6375			

- ※ \*The channel is set to No. 74 (434.000 MHz) for shipment.
- ※ \*If you intend to use several SLR-434M units in the same area, use a channel plan that takes into account radio interference due to third-order intermodulation.

Circuit Design provides a computational tool on our website for creating channel plans that avoid interference due to third-order intermodulation.

Calculation tool: <http://www.cdt21.com/resources/siry06.asp>

## 8. UART port communication settings

The serial communication conditions for the UART port of this product are as follows.

Communication speed	19,200 bps	Fixed value Cannot be changed.
Data	8-bit	
Parity	None	
Stop	1-bit	
Flow control	Hardware: RTS/CTS pin (Software flow: Xon/Xoff is not used)	

(The RTS output terminal is normally Lo. When the CTS input terminal is “Hi”, UART data is not output)

Note: The UART serial communication terminals (TXD/RXD/RTS/CTS) cannot be connected directly to a PC or other Com port because the signal level and logic is different.

## 9. Serial communication commands

The table below shows examples of the basic commands and responses.

See the operation guide "SLR-434M Serial Communication" for details and other command values.

Item	Commands	Value (hex)	Options	Response example	Content (with a response example)
Radio communication mode setting	@MO	00		*WR=PS *MO=00 FSK BIN MODE	Sets the communication mode to FSK binary mode.  The value set is automatically saved and the device restarts.
		01		*WR=PS *MO=01 FSK CMD MODE	Sets the communication mode to FSK command mode.  A character string that indicates the mode of the response example is output after restarting.
		02		*WR=PS *MO=02 LORA BIN MODE	Sets the communication mode to LoRa® binary mode.  In the binary mode, it is not possible to receive any commands, therefore it is necessary to set the INI terminal to Low for more than 3 seconds to return to the command mode.
		03		*WR=PS *MO=03 LORA CMD MODE	Sets the communication mode to LoRa® command mode.
LoRa® mode Number of chips setting	@SF	00	/W	*SF00 *WR=PS *SF00	Sets the number of chips in LoRa® mode to 128 chips.
Channel setting	@CH	4A	/W	*CH1B *WR=PS *CH1B	Sets the communication frequency to 434.000 MHz (See '7.Communication frequency table'.)
ID setting (Equipment, Target station, Group ID)	@EI	0A		(With Equipment ID) *EI=0A	Sets the Equipment ID (local station) to "0A"  (Sets the ID for identifying each radio station and the other party in communication.)
	@DI @GI		/W	*WR=PS *EI=0A	
Transmit data	@DT	05abcde		*DT=05	Sends the 5-byte data "abcde".
Receive data				*DR=05abcde	Indicates that the 5-byte data "abcde" was received.
RSSI acquisition for the last data received.	@RS			*RS=-100dBm	Acquires the RSSI level (strength of the radio waves of the received signal) for the last data received.
Current RSSI acquisition	@RA			*RA=-120dBm	Acquires the current RSSI level (radio wave strength) of the channel set.
Contact function IO setting	@PS	0F	/W	*PS =0F *WR=PS *PS=0F	Sets contacts DIO1 to DIO4 as input ports and DIO5 to DIO8 as output ports.
Contact state check and setting	@PO	10	/W	*PO=10 *WR=PS *PO=10	Sets contact DIO5 to Hi. Acquires the status if it is the input port.
Target station contact state check and setting	@PT			*PT=10 *PR=040280	Acquires the contact information of the target station. (" * PR =..." shows the response from the target station.)
		20		*PT=20 *PR=040220	Sets the contact status of the target station. (" * PR =..." shows the response from the target station.)

Contact communication mode setting	@PM	01	/W	*PM=01 *WR=PS *PM=01	If the status of the contacts set to input changes, the contact information is transmitted automatically (once). If the target station receives this signal, the status of the corresponding contact output changes.
Initializing	@IZ			*WR=PS *IR=OK LORA CMD MODE	Sets the parameters back to the factory settings.

After command + value + data (optional), add the line feed code 'CR' 'LF'.

If you omit value + data, you can check the content of the current settings.

If the optional '/W' is added, the setting value is saved, and it becomes the initial value next time the power is switched on.

## Important notice

- Customers are advised to consult with Circuit Design sales representatives before ordering. Circuit Design believes the provided information is accurate and reliable. However, Circuit Design reserves the right to make changes to this product without notice.
- Circuit Design products are neither designed nor intended for use in life support applications where malfunction can reasonably be expected to result in significant personal injury to the user. Any use of Circuit Design products in such safety-critical applications is understood to be fully at the risk of the customer and the customer must fully indemnify Circuit Design, Inc for any damages resulting from any improper use.
- As the radio module communicates using electronic radio waves, there are cases where transmission will be temporarily cut off due to the surrounding environment and method of usage. The manufacturer is exempt from all responsibility relating to resulting harm to personnel or equipment and other secondary damage.
- The manufacturer is exempt from all responsibility relating to secondary damage resulting from the operation, performance and reliability of equipment connected to the radio module.

### Copyright

- All rights in this operation guide are owned by Circuit Design, Inc. No part of this document may be copied or distributed in part or in whole without the prior written consent of Circuit Design, Inc.

## Cautions

- Do not use the equipment within the vicinity of devices that may malfunction as a result of electronic radio waves from the radio module.
- Communication performance will be affected by the surrounding environment, so communication tests should be carried out before actual use.
- Ensure that the power supply for the radio module is within the specified rating. Short circuits and reverse connections may result in overheating and damage and must be avoided at all costs.
- Ensure that the power supply has been switched off before attempting any wiring work.
- The case is connected to the GND terminal of the internal circuit, so do not make contact between the '+' side of the power supply terminal and the case.
- When batteries are used as the power source, avoid short circuits, recharging, dismantling, and pressure. Failure to observe this caution may result in the outbreak of fire, overheating and damage to the equipment. Remove the batteries when the equipment is not to be used for a long period of time. Failure to observe this caution may result in battery leaks and damage to the equipment.
- Do not use this equipment in vehicles with the windows closed, in locations where it is subject to direct sunlight, or in locations with extremely high humidity.
- The radio module is neither waterproof nor splash proof. Ensure that it is not splashed with soot or water. Do not use the equipment if water or other foreign matter has entered the case.
- Do not drop the radio module or otherwise subject it to strong shocks.
- Do not subject the equipment to condensation (including moving it from cold locations to locations with a significant increase in temperature.)
- Do not use the equipment in locations where it is likely to be affected by acid, alkalis, organic agents or corrosive gas.
- Do not bend or break the antenna. Metallic objects placed in the vicinity of the antenna will have a great effect on communication performance. As far as possible, ensure that the equipment is placed well away from metallic objects.
- The GND for the radio module will also affect communication performance. If possible, ensure that the case GND and the circuit GND are connected to a large GND pattern.

## Warnings

- Do not take apart or modify the equipment.
- Do not remove the product label (the label attached to the upper surface of the module.) Using a module from which the label has been removed is prohibited.

Copyright 2020, Circuit Design, Inc.

## Revision History

Version	Date	Description	Remark
0.91	Feb. 2017	Provisional Edition	
1.0	Jan. 2018		
2.0	Mar. 2020	@IZ added, Registered trademark symbol added to LoRa®	

The copyright of this manual belongs to Circuit Design, Inc. Reproduction, duplication or modification of part or all of this manual without permission is prohibited.